

Application Guide for Mobile Communication

Application Guide

About this document

This Application Guide for Mobile Communication presents recent trends in Radio Frequency applications including suggestions for using the latest Infineon products. It is a reference book to help mobile phone design experts to find the right parts easily for building high-performance RF Front Ends. The following subjects are covered:

1. Overview of Infineon Technologies AG's RF product portfolio
2. RF switches in mobile phones and wireless systems
3. Low Noise Amplifiers for mobile phones
4. LNAs and FE modules and other RF devices for global navigation satellite systems
5. RF devices for Wireless Local Area Network, unlicensed LTE and Licensed Assisted Access
6. RF devices for FM radio and mobile TV
7. Electrostatic Discharge protection devices for mobile phones

Infineon Technologies

A Leading Company in RF and Sensors

Infineon Technologies focuses on the three central challenges facing modern society: **Energy Efficiency, Mobility and Security**. It offers semiconductor components and system solutions for automotive, industrial, mobile, wireless, consumer, chip-card and security applications.

Infineon's products stand out for their reliability, their quality excellence and their innovative and leading-edge technologies in analog and mixed signal, RF and power, as well as embedded control.

With its technologies and design expertise, Infineon is the market leader in its focused segments. Infineon has more than 60 years of experience in developing RF products for numerous applications and always plays a leading role in the market with high performance, yet cost effective products. You can visit our website www.infineon.com to learn more about the broad product portfolio of Infineon Technologies.

The Infineon business unit - RF and Sensors (RFS) - has evolved over the years from a supplier of standard RF discrete components such as transistors and diodes to an advanced portfolio of state-of-the-art, innovative and differentiated products including application specific Microwave Monolithic Integrated Circuits (MMICs), millimeter-wave transceivers, RF power amplifiers, sensors and ESD protection components. Please visit our website www.infineon.com under the categories "RF & Wireless Control", "Sensors IC" or "ESD & EMI" to learn more about Infineon's latest RF, Sensor and Protection products for your applications.

Infineon's RFS application guides with three different brochures are an easy-to-use tool primarily meant for engineers to guide them to the right devices for their system efficiently. These application guides are updated frequently to include latest applications and trends. Each brochure focuses on one of our major market segments:

1. Application Guide for Mobile Communication: www.infineon.com/appguide_rf_mobile
2. Application Guide for Industrial Applications: www.infineon.com/appguide_rf_industrial
3. Application Guide for Protection: www.infineon.com/appguide_esd_protection

Our application experts worldwide are always ready to support you in designing your systems with our devices. Please contact [Infineon's Regional Offices](#) or one of [Infineon Worldwide Distribution Partners](#) in your area to get all the support you might need.

Kind Regards,

Dr. Heinrich Heiss
Head of Technical Marketing
& Application Engineering, RFS



Dr. Chih-I Lin
Group Leader of Technical Marketing
& Application Engineering RF Devices, RFS





Table of Contents

About this document	1
Infineon Technologies	1
1 Infineon’s RF and Protection Devices for Mobile Communication	4
2 High-/Medium-Power Switches for Mobile Phones and Wireless Systems	9
2.1 Key Challenges of Antenna Switches in Modern Mobile Applications	11
2.2 MIPI Control Interfaces for Mobile Phone Industry	13
2.2.1 MIPI RFFE – Mobile Industry Processor Interface for RF Front-End Devices	14
2.2.2 The current specification version from the MIPI Alliance is 1.10	15
2.3 High- and Medium-Power RF Switches	16
2.3.1 Antenna Switch Modules for Main Path.....	16
2.3.2 Ultra-High Linearity Switches	17
2.3.3 Diversity Antenna Switches	18
2.3.4 Band-selection Switches in a Single-ended Configuration	19
2.3.5 Cross Switches.....	20
2.3.6 Band-selection Switches in a Differential Configuration.....	21
2.4 Antenna Tuning Switches	22
2.4.1 Antenna Impedance Matching.....	22
2.4.2 Antenna Aperture Tuning.....	23
2.4.3 System Approach to Aperture Tuning	23
2.4.4 Key Parameters of Antenna Tuning Switches	25
2.5 PIN Diode Switches	26
2.5.1 Antenna Switch with PIN Diodes and Power Detection with Schottky Diodes.....	27
2.5.2 Ultra-Low-Harmonic-Generation Band Switch with PIN Diodes.....	28
2.5.3 Antenna Switching with PIN Diodes (I)	29
2.5.4 Antenna Tuning with PIN Diodes (II).....	29
2.5.5 Bypass Path for Low Noise Amplifiers	29
3 High-sensitivity Mobile RF Front-End with Low Noise Amplifiers	30
3.1 Key Challenges of LNAs in Mobile Applications	32
3.2 Single-band LNAs and Multiple-band LNA Banks	33
3.2.1 Single-band LNAs	33
3.2.2 Multiple-Band LNA Banks	34
3.3 LNA Multiplexer Modules for Carrier Aggregation.....	36
3.4 LNAs for 3.5 GHz TD-LTE Modems.....	38
4 Global Navigation Satellite Systems.....	39
4.1 Key Features of GNSS Front-End Components	41
4.1.1 Key Features of Low Noise Amplifiers (LNAs)	41
4.1.2 Key Features of Surface Acoustic Wave (SAW) Filters	41
4.2 System Challenges for Modern GNSS Reception in Mobile Devices.....	42
4.3 RF Front-End Devices for GNSS.....	45
4.4 Integrated Front-End Modules for GNSS.....	47
5 Wireless-LAN, Unlicensed LTE (LTE-U) and Licensed Assisted Access (LAA)	48
5.1 Wireless-LAN Applications	48
5.1.1 Key Features of WLAN Rx Front-End Devices	50

5.1.2	Dual-Band (2.4–6.0 GHz) WLAN (IEEE 802.11a/b/g/n) Front-End	51
5.1.3	MIMO Configurations for WLAN (IEEE 802.11b/g/n and IEEE 802.11a/n/ac) Applications.....	52
5.1.4	WLAN (IEEE 802.11a/b/g/n) Front-End Devices.....	53
5.2	Unlicensed LTE (LTE-U) and Licensed Assisted Access (LAA)	55
5.2.1	LTE-U and LAA as data rate booster for LTE-A	55
5.2.2	LTE-U and LAA Front-End Devices	57
6	FM Radio and Mobile TV	58
6.1	FM Radio with Embedded Antenna	59
6.2	TV Reception in Mobile Phones	61
6.3	TV Reception with Band Selection Switch	63
6.4	FM and TV Reception in Mobile Phones with Band Selection Switch	64
7	ESD and ESD/EMI Interface Protection.....	65
7.1	Interface Protection with TVS Protection Diodes	66
7.2	Interface Protection with Integrated ESD/EMI Devices	68
7.3	Near-Field Communication.....	69
7.4	Reverse Polarity Protection (RPP) for USB Charger.....	71
Abbreviations		72
Alphanumerical List of Symbols.....		73
Package Information		74
Support Material.....		76

1 Infineon's RF and Protection Devices for Mobile Communication

Mobile phones represent the largest worldwide market in terms of both volume and number of applications on a single platform today. More than 1.5 billion phones are shipped per year worldwide. The major wireless functions in a mobile phone include a 2G/3G/4G (GSM/EDGE/CDMA/UMTS/WCDMA/LTE/LTE-A/TD-SCDMA/TD-LTE) cellular modem, and wireless connectivity systems such as Wireless Local Area Network (WLAN), Global Navigation Satellite System (GNSS), broadcasting receivers and Near-Field Communication (NFC).

Moving towards 4G Long-Term Evolution-Advanced (LTE-Advanced), the number of LTE bands has exploded in the last few years. Currently, there are 44 LTE bands worldwide for LTE systems. The following table, derived from the latest release of **3GPP TS 36.101 V12.7.0 "Evolved Universal Terrestrial Radio Access (E-UTRA) - User Equipment (UE) radio transmission and reception"** in April 2015, shows the LTE band numbers with up-/down-link frequency ranges and their related multiplexing methods:

Band No.	Band Definition	Uplink Frequency Range	Downlink Frequency Range	FDD/TDD System	Comment
1	Mid-Band	1920-1980 MHz	2110-2170 MHz	FDD	
2	Mid-Band	1850-1910 MHz	1930-1990 MHz	FDD	
3	Mid-Band	1710-1785 MHz	1805-1880 MHz	FDD	
4	Mid-Band	1710-1755 MHz	2110-2155 MHz	FDD	
5	Low-Band	824-849 MHz	869-894 MHz	FDD	
6	Low-Band	830-840 MHz	875-885 MHz	FDD	
7	High-Band	2500-2570 MHz	2620-2690 MHz	FDD	
8	Low-Band	880-915 MHz	925-960 MHz	FDD	
9	Mid-Band	1749.9-1784.9 MHz	1844.9-1879.9 MHz	FDD	
10	Mid-Band	1710-1770 MHz	2110-2170 MHz	FDD	
11	Mid-Band	1427.9-1452.9 MHz	1475.9-1500.9 MHz	FDD	
12	Low-Band	698-716 MHz	728-746 MHz	FDD	
13	Low-Band	777-787 MHz	746-756 MHz	FDD	
14	Low-Band	788-798 MHz	758-768 MHz	FDD	
15		reserved	reserved	FDD	
16		reserved	Reserved	FDD	
17	Low-Band	704-716 MHz	734-746 MHz	FDD	
18	Low-Band	815-830 MHz	860-875 MHz	FDD	

Band No.	Band Definition	Uplink Frequency Range	Downlink Frequency Range	FDD/TDD System	Comment
19	Low-Band	830-845 MHz	875-890 MHz	FDD	
20	Low-Band	832-862 MHz	791-821 MHz	FDD	
21	Mid-Band	1447.9-1462.9 MHz	1495.9-1510.9 MHz	FDD	
22	High-Band	3410-3500 MHz	3510-3600 MHz	FDD	
23	Mid-Band	2000-2020 MHz	2180-2200 MHz	FDD	
24	Mid-Band	1626.5-1660.5 MHz	1525-1559 MHz	FDD	
25	Mid-Band	1850-1915 MHz	1930-1995 MHz	FDD	
26	Low-Band	814-849 MHz	859-894 MHz	FDD	
27	Low-Band	807-824 MHz	852-869 MHz	FDD	
28	Low-Band	703-748 MHz	758-803 MHz	FDD	
29	Low-Band	N/A	716-728 MHz	FDD	
30	High-Band	2305-2315 MHz	2350-2360 MHz	FDD	
31	Low-Band	452.5-457.5 MHz	462.5-467.5MHz	FDD	
32	Mid-Band	N/A	1452-1496 MHz	FDD	
33	Mid-Band	1900-1920 MHz		TDD	
34	Mid-Band	2010-2025 MHz		TDD	
35	Mid-Band	1850-1910 MHz		TDD	
36	Mid-Band	1930-1990 MHz		TDD	
37	Mid-Band	1910-1930 MHz		TDD	
38	High-Band	2570-2620 MHz		TDD	
39	Mid-Band	1880-1920 MHz		TDD	
40	High-Band	2300-2400 MHz		TDD	
41	High-Band	2496-2690 MHz		TDD	
42	High-Band	3400-3600 MHz		TDD	
43	High-Band	3600-3800 MHz		TDD	
44	Low-Band	703-803 MHz		TDD	

Note: FDD: Frequency Division Duplexing; TDD: Time Division Duplexing

The mobile technologies for smartphones have seen phenomenal growth in recent times. The data rate of mobile devices has increased significantly over the evolution of modern mobile technologies from the first 3G/3.5G technologies (Universal Mobile Telecommunications System (UMTS) and Wideband-Code Division Multiple Access (WCDMA), High-Speed Packet Access (HSPA) and Evolved High-Speed Packet Access (HSPA+)) to 4G LTE-Advanced (LTE-A). The ability of 4G LTE-A to support bandwidths up to 20 MHz and to have more spectral efficiency by using high order modulation schemes such as Quadrature Amplitude Modulation (QAM-64) is of particular importance as the demand for higher wireless data speeds continues to

grow rapidly. LTE-A can aggregate up to 5 carriers (up to 100 MHz) to increase user data rates and capacity for high-speed applications. These new technical features for mobile high-data-rate communication, and advanced wireless connectivities can be summarized as following:

- Inter-operation Frequency Division Duplexing (FDD) + Time Division Duplexing (TDD) systems
- Down-/uplink Carrier Aggregation (CA)
- LTE-U and LAA at 5 to 6 GHz using link aggregation or carrier aggregation
- Adaptive antenna systems
- Multiple-Input Multiple Output (MIMO) at RF FEs
- Device-to-Device (D2D) communication with LTE (LTE-D)
- High speed wireline connection with USB 3.0, Bluetooth 4.0 etc.

They drive the industry to develop new concepts for Radio Frequency (RF) Front-Ends (FEs) and the antenna system and digital interface protection. These require microwave semiconductor vendors to offer highly integrated and compact devices with lower loss rates, and more powerful and linear performance. The key trends in RF components for mobile phone are:

- Microwave Monolithic Integrated Circuits (MMICs) with smaller form factors
- Higher levels of integration with control buses
- Higher RF power capability
- Ability to handle increased number of bands and modes
- Better immunity to interfering signals
- Frequency tunability
- Higher integration of various functions in one package

As a result of the coexistence of various wireless functions, cross-functional interference becomes much more complicated. Using our extensive application know-how, knowledge about application trends, and industry contacts, all our products are designed to fit into their respective applications to meet industry standards. This simplifies the design and makes choosing the right device easier for the system designers.

All applications described in this document are depicted with simple block diagrams to show the various building blocks, followed by short descriptions. Infineon's recommended devices for each application are tabulated together with their most important performance characteristics. More detailed information on each product including **datasheet, application notes, device libraries with Spice models and S-parameter files, products and application brochures, sample kits etc.** is available on Infineon's website www.infineon.com/rfandprotectiondevices by clicking on the specific product name.

Infineon product portfolio for mobile phone applications: Infineon offers most of the important building blocks for RF FE systems. Our product portfolio addresses requirements for these high-performance RF

devices by offering RF MMIC LNAs, RF Complementary Metal-Oxide-Semiconductor (CMOS) switches, RF modules, antenna-tuning devices, RF couplers, RF transistors and diodes, and RF Electro-Static Discharge/ Electromagnetic Interference (ESD/EMI) devices with optimal performance and low power consumption. Infineon offers products for cellular modems, wireless connectivity functions, broadcasting receivers, sensors, ESD/EMI interface devices and more. The following block diagrams illustrate the product portfolio offered by Infineon for mobile communication.

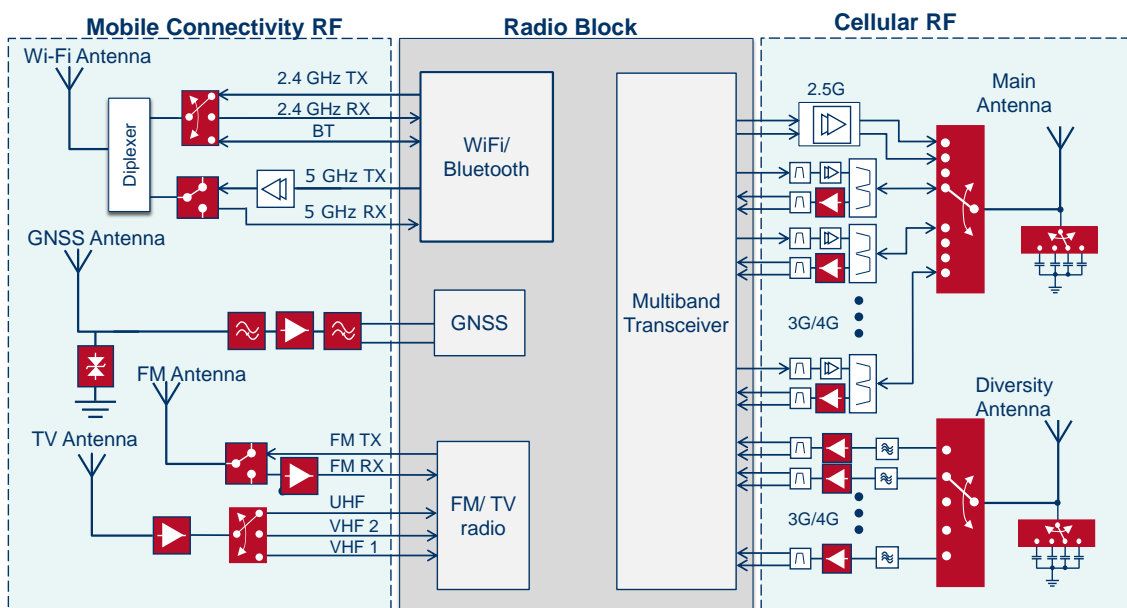

Overview of Infineon's products for mobile devices

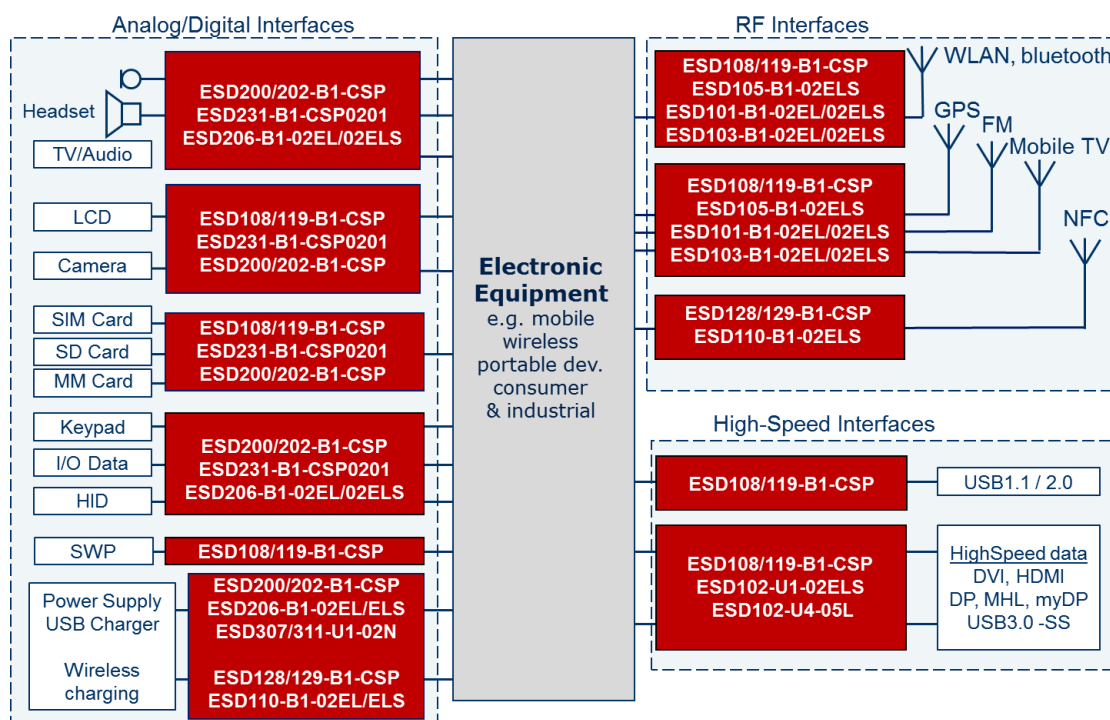

Overview of Infineon's ESD protection devices

Infineon supports customers with system know-how to design RF front-ends: Infineon provides design-in support for Infineon's RF FE and protection products, as well as collaboration with its customers and partners on the mobile phone RF system level to define the best solution for their requirements. By using various system-level simulation tools with behavior models, system-level test equipment, and reference hardware for RF FE total solutions, Infineon can demonstrate and optimize system performance to reduce time-to-market. The following pictures show one example. The upper graphic illustrates a mobile diversity receiver simulation environment, and the lower graphic shows the related block diagram and the hardware implemented for performance verification of the simulation results.

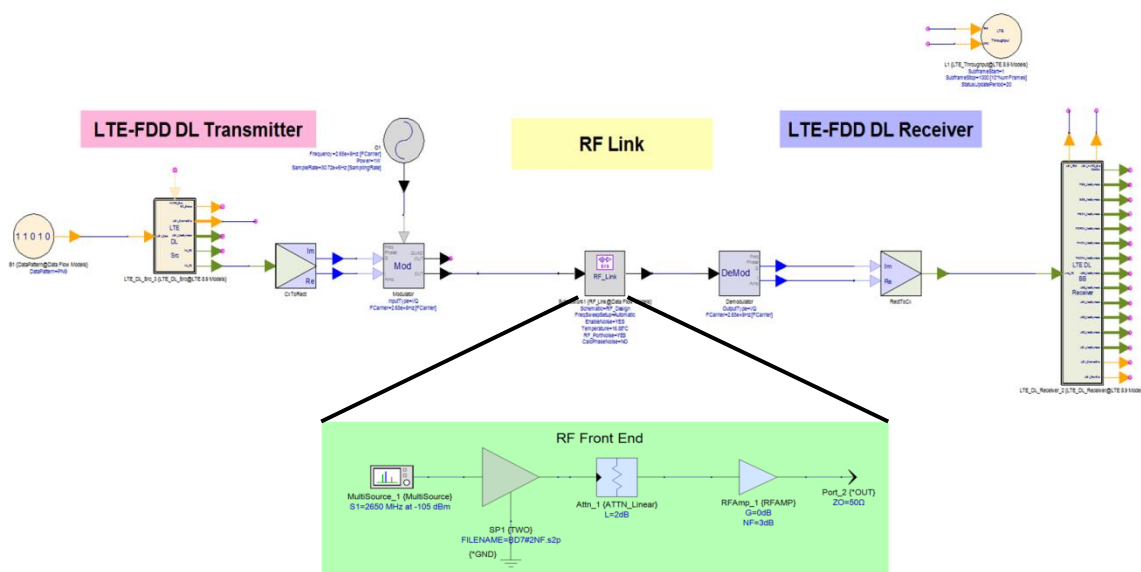

Simulation environment of receiver diversity path

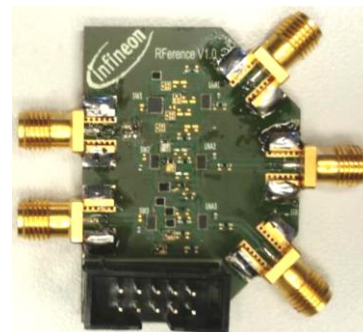
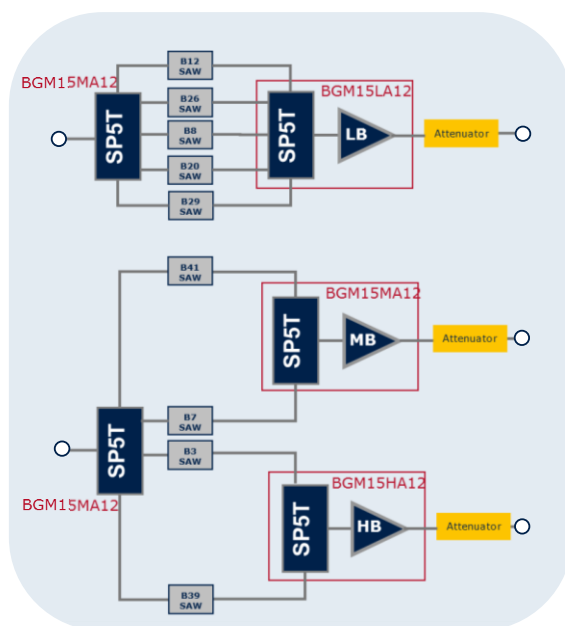

Block diagram and implemented hardware for verification

2 High-/Medium-Power Switches for Mobile Phones and Wireless Systems

Infineon's broad portfolio of Radio Frequency (RF) switches includes high-performance devices with low Insertion Loss (IL), high isolation and low harmonics generation. Besides RF switches for main and diversity paths for high-volume production, Infineon uses a proprietary RF-Complementary Metal-Oxide-Semiconductor (CMOS)-based process on silicon substrate for its RF switches.

These switches can also be built using other technologies such as Silicon-on-Insulator (SoI), Silicon-on-Sapphire (SoS), Gallium Arsenide (GaAs), or the more classical PIN diodes. However, using CMOS design on Si substrate offers many advantages, such as integration scale, volume production, reliability and costs, over its counterparts. The CMOS process also enables biasing and control circuitry to be integrated on the same die. Control logic interfaces such as General Purpose Input/Output (GPIO), Serial Peripheral Interface (SPI) or RF Front-End Mobile Industry Processor Interface (RFFE-MIPI) are fully integrated. CMOS-compatible logic levels eliminate the need for external level shifters. This simplifies the design process, and reduces external part count.

This technology also ensures that no Direct Current (DC) voltage is present at the RF ports. That means no external blocking capacitors are required at RF ports in case there is no DC voltage is on the RF traces. For example, a passive device such as a Surface-Acoustic-Wave (SAW) or a Bulk-Acoustic-Wave (BAW) filter can be connected directly to our RF switches.

Infineon's RF CMOS switches are the first on the market to be based purely on standard industrial CMOS processes that offer low insertion loss, high isolation and low harmonics generation for high-volume production. They are widely used for band selection/switching or diversity switching at the antenna or different RF paths within the RF Front-End (FE).

The classical approach of using PIN diodes as switches is obsolete. PIN diodes have high current consumption and slow switching speeds. They require many external components for complex modern mobile phone systems. Infineon's RF CMOS technologies with its high integration capability is thus the technology of choice for RF switches that are small, inexpensive, have integrated control logic circuits, and require zero external components. In addition to all the above advantages, CMOS switches offer excellent Electro-Static Discharge (ESD) robustness.

Infineon offers a wide variety of switches and Antenna Switch Modules (ASMs) ranging from simple switches such as simple Single-Pole Double-Throw (SPDT) switches to complex high port count configurations, e.g. Single-Pole Ten-Throw (SP10T) or Double-Pole Fourteen-Throw (DP14T) switches. Their power capability

ranges from medium (+20 dBm) to high power (+36 dBm). Infineon also has differential RF-switch designs such as Double-Pole Double-Throw (DPDT) devices.

As for the main path ASM components, Infineon is using its compact Integrated Passive Device (IPD) technology to integrate harmonic filters for Global System for Mobile Communication (GSM) transmission frequencies in miniature module packages. The main antenna switch must be highly linear to provide high isolation between transmit and receive chains, with the lowest insertion loss possible.

For architectures that integrate new features such as downlink inter-band carrier aggregation to increase downstream data rates, ASMs are facing new challenges as they have to route two signals, received in different frequency bands, simultaneously. The new switches with multiple ports such as the SP7T+SP7T, or the DP14T, can be used for these kinds of applications.

Infineon's RF switches are delivered either in discrete Thin Small Leadless Package (TSLP) or Thin Small Non-leaded Package (TSNP) packaged components or as Chip-Scale-Packages (CSPs) with a pin pitch much smaller than 180 μm for module manufacturers.

Infineon also supports chip-set makers' reference designs with dedicated products whose RF performance and control interface will meet chip-set requirements. Infineon products make it easy to use and fast to design customer systems.

Infineon also has devices in its RF switch portfolio that are suitable for inter-band and intra-band carrier aggregation. Infineon offers system know-how that can help customers select the best products with respect to filters and Low Noise Amplifiers (LNAs). The devices support carrier aggregation from a control logic point-of-view. Devices such as BGSF1717MN26 have a fixed Truth Table (TT), matching the definition of a mobile phone chip set. Other devices such as BGS15MA12 use a TT with direct mapping, meaning that each RF path has only one bit in the MIPI command.

Please visit our website www.infineon.com/rfswitches for more details on RF switches for mobile phone and all wireless applications, or contact your local Infineon or sales representative.

2.1 Key Challenges of Antenna Switches in Modern Mobile Applications

Smartphones today can operate across several cellular bands including GSM/ EDGE/ CDMA/ UMTS/ WCDMA/ LTE/ LTE-A/ TD-SCDMA/ TD-LTE. The design of the RF FE part in modern mobile phones is becoming increasingly complex and demanding due to the increasing number of frequency bands and modes in which the phone needs to operate. One of the main components of a RF FE is the antenna switch that selects which Transmitter (TX)/Receiver (RX) path can be connected to the antenna. The RF switch has to satisfy high linearity requirements. This section presents some of the main challenges of antenna switches in mobile applications.

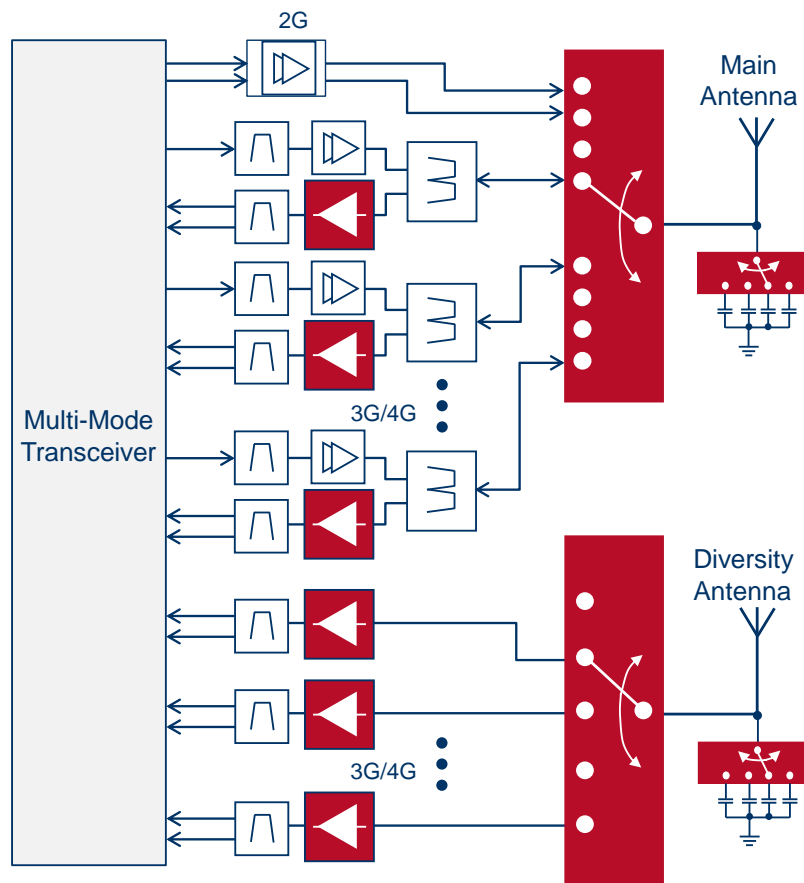

Typical RF FE in a mobile phone

Insertion Loss (IL)

IL is an important parameter since the RF switch is placed between the antenna and the radio. Any increase of IL results in an increased system Noise Figure (NF) in the receiver path and wastes transmit power, which reduces connectivity distance and battery lifetime.

High Isolation (Iso)

Isolation between ports is the measure of the signal suppression in excess of the IL between the “off” ports. High isolation in switches is desired to minimize the interference or leakage from other ports.

Compression Point (P1dB or P0.1dB)

Compression Point is a measure of high power capability for RF front-end switches. The P0.1dB specifies the input power level at the switch in dBm at which the IL of the switch increases by 0.1 dB compared to the value in the linear region with small signal operation. This value confirms the power handling capability of the switch. Infineon’s switches are measured up to an input power of 30 to 40 dBm without observable deterioration in the IL.

Harmonic Generation (2nd Harmonics H2 and 3rd Harmonics H3)

Harmonic generation is an important parameter for the characterization of a RF switch. RF switches for mobile phones have to deal with high RF levels, up to 36 dBm, even with strongly mismatched conditions. Harmonics are generated with this high RF power at the input of the switch. These harmonics (e.g. 2nd and 3rd) can disturb other reception bands or cause interference in other RF applications (Global Positioning System (1575.42 MHz) (GPS), Wireless Local Area Network (WLAN)) within the same mobile phone or in mobile phones nearby.

Intermodulation Distortion (IMD2 and IMD3)

IMD is the linearity parameter of the device under multi-tone conditions. The intermodulation between each frequency component generates undesired outputs at the sum and difference frequencies of the input tones and at multiples of those sum and difference frequencies. The intermodulation products increase the spread of the signal spectrum which leads to adjacent channel interference.

Digital Control Interface

Traditionally, switches are controlled through the parallel GPIO scheme, which involves a set of parallel control lines with pre-defined “high” and “low” logic. This is mainly used for all low-complexity RF switches. More and more designs are moving from this parallel interface to a serial one, such as Serial Peripheral Interface (SPI). Mobile chipset companies formed the Mobile Industry Processor Interface (MIPI) alliance, aiming to standardize communication between all major components in mobile devices with structured register commands. Meanwhile all companies are adopting MIPI and requiring RF switches used in their mobile devices to be MIPI-compatible.

2.2 MIPI Control Interfaces for Mobile Phone Industry

The MIPI Interface (Mobile Industry Processor Interface) contains 20 standardized interfaces for mobile phone device platforms such as:

- **RFFE**, a two-wire serial bus for control of **RF Front-End** components, e.g. LNAs or RF-Switches
- **SoundWire**, a Two-wire time-division bus supporting multiple clocks, also audio clocks for audio broadcast, e.g. microphones or speaker.
- **SensWire** (Sensor IF), a 2-pin interface that is backward compatible to I2C standard and is comparable to SPI for sensors, e.g. pressure sensors.

An overview about MIPI interfaces in a Mobile platform is pictured below.

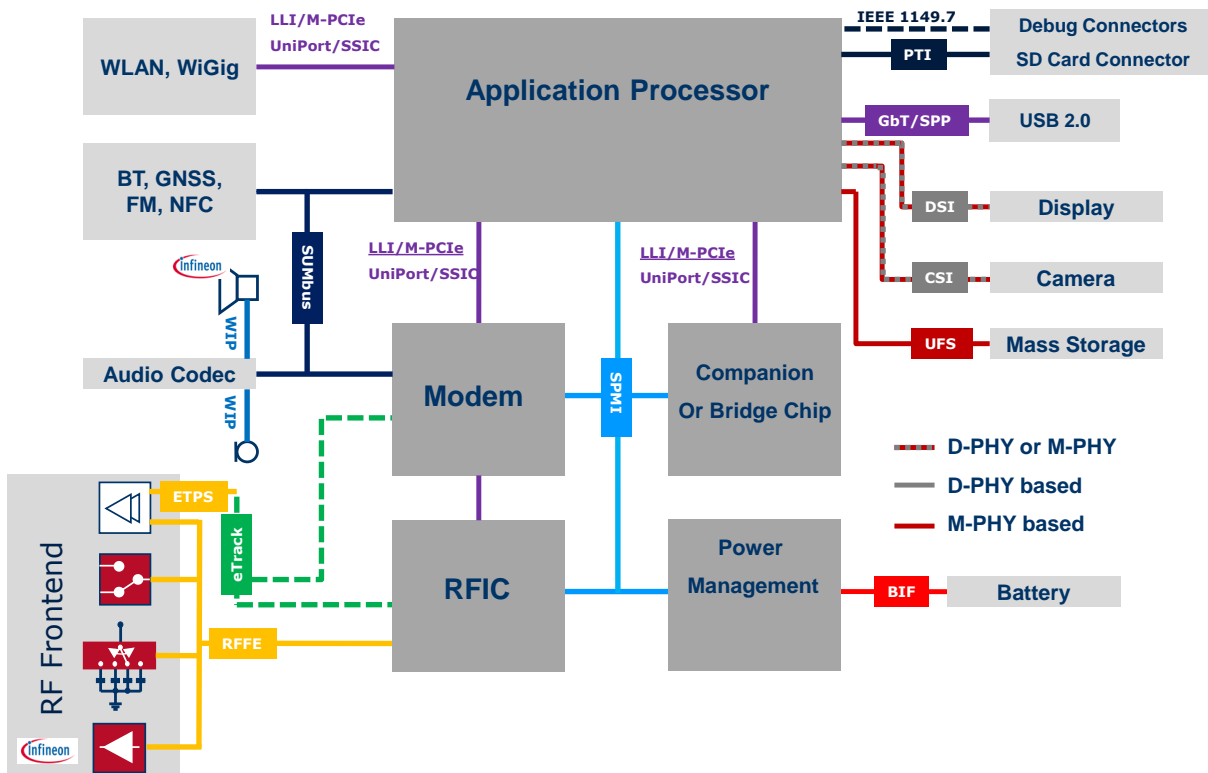

2.2.1 MIPI RFFE – Mobile Industry Processor Interface for RF Front-End Devices

MIPI RFFE is the common control interface in Mobile Phone Devices due to the becoming higher complexity of their RF Front-End systems. There are more and more band used, 2x Rx CA is currently implemented and 3x CA Rx and 2x CA Tx is in preparation for the next generation of Mobile Phones. Therefore, to reduce control line complexity and RF IC pin count the MIPI RFFE interface is mostly used and will have more and more priority in future

RFFE is a flexible two-wire serial bus, designed primarily for control of RF Front-End components, that allows for very simple to complex Slave devices. One bus master can write and read up to 15 devices, such as power amplifiers, sensors, switch modules, and antenna tuners. RFFE includes a group trigger function for timing-critical events and provisions for low current consumption and low EMI. Below, a typical MIPI bus structure is shown below.

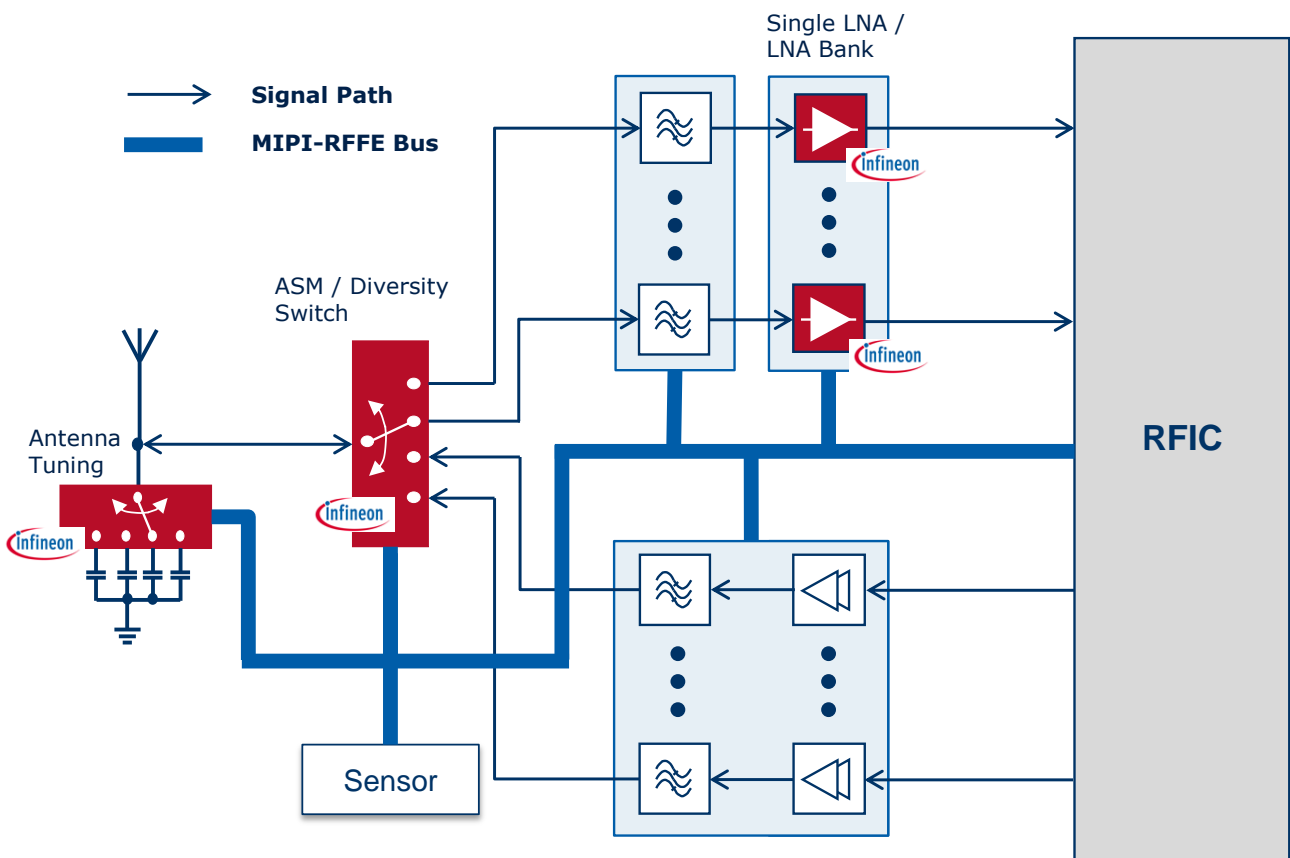

2.2.2 Specification V1.10 of MIPI Alliance

The MIPI RFFE Bus can support a speed of 32 kHz to 26 MHz or even 52 MHz in future. The VIO voltages support 1.2 and/or 1.8 Volts. The bus protocol is a Single-ended signalling for a clock line, along with a bidirectional data line, in a point-to-multipoint configuration. The structure (picture below) is defined with one Master (RFIC) and up to 15 slaves as LNAs, switches or antenna tuners.

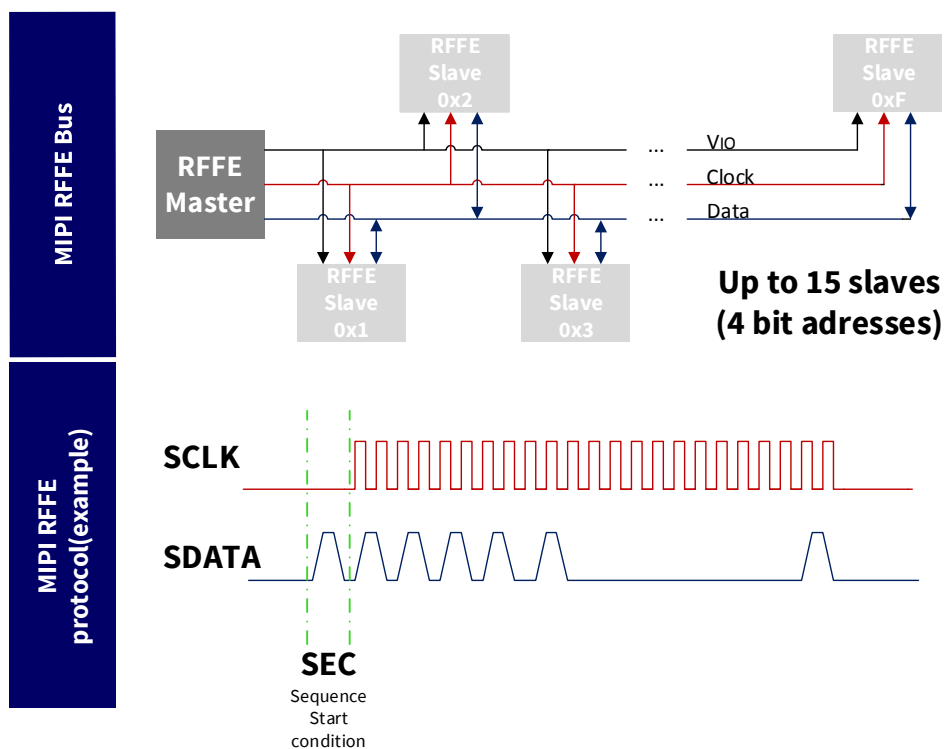

MIPI RFFE Specifications:

- MIPI RFFE commands/ protocols (Register Write, Register0 Write, ...)
- Registers: e.g. Register 0, PM_Trig, Product_ID, Manufacturer_ID and MAN_USID Register
- Timing information and VIO voltage levels for 1.2V and 1.8V bus mode
- Trigger functionality, Programmable USID
- MIPI RFFE ID's: USID, BSID, GSID, Product ID and Manufacturer ID

The **MIPI RFFE specification defines the basic functionality of the RFFE Bus** but it also provides the degree of freedom to specify additional registers, customer related features and default values. Please refer to MIPI Alliance for more details about the MIPI interface standards: <http://www.mipi.org/about-mipi/mipi-interfaces-mobile-platform>

2.3 High- and Medium-Power RF Switches

2.3.1 Antenna Switch Modules for Main Path

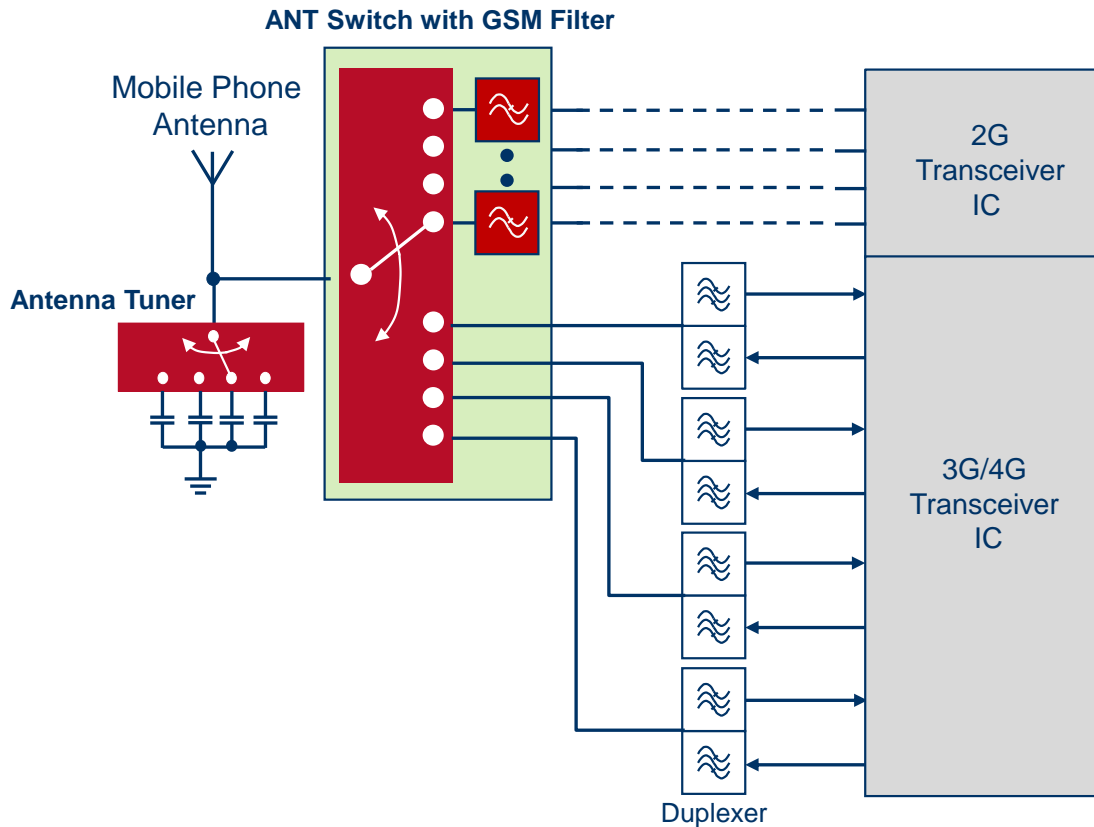

RF CMOS antenna switch module

Antenna Switch Modules for Main Antenna

Product	Type	App. Note	V _{dd} [V]	V _{ctrl} ¹⁾ [V]	IL ²⁾ [dB]	Iso. ³⁾ [dB]	P _{in,max} ⁴⁾ [dBm]	Ctrl. Int. ⁵⁾	Package
BGSF18DM20	SP8T	AN247 AN284	2.85 ... 4.7	1.6... 3.5	0.6 / 0.7 (TRx) / 1.0 / 1.0 (Tx)	40/35	32(TRX)/ 36 (TX)	SPI	VCCN-20-1
BGSF110GN26	SP10T	AN306	2.4... 3.3	1.35 ...V _{dd}	0.5 / 0.58(TRx)/ 0.9 / 1.0 (Tx)	40/25	30(TRX)/ 36 (TX)	GPIO	TSNP-26-2
BGSF1717MN26	CA 2x SP7T	on request	2.4... 5.5	1.05...1. 95	0.5 / 0.6(TRx)/ 0.9 / 1.0 (Tx)	38/27	30(TRX)/ 36 (TX)	RFFE MIPI	TSNP-26-3

Notes: 1) Digital Control Voltage (logic high); 2) IL = Insertion Loss at 1.0/2.0 GHz; 3) Isolation at 1.0/ 2.0 GHz from RF_{in} to RF port; 4) Maximum input power; 5) Control Interface; 6) Please visit www.infineon.com/rfswitches for alternative devices.

Carrier-Aggregation-Capable Antenna Switch Modules for Main Antenna

Product	Type	App. Note	V _{dd} [V]	V _{ctrl} ¹⁾ [V]	IL ²⁾ [dB]	Iso. ³⁾ [dB]	P _{in,max} ⁴⁾ [dBm]	Ctrl. Int. ⁵⁾	Package
BGSF1717MN26	CA 2x SP7T	on request	2.4... 5.5	1.05...1. 95	0.5 / 0.6(TRx)/ 0.9 / 1.0 (Tx)	38/27	30(TRX)/ 36 (TX)	RFFE MIPI	TSNP-26-3

Notes: 1) Digital Control Voltage (logic high); 2) IL = Insertion Loss at 1.0/2.0 GHz; 3) Isolation at 1.0/ 2.0 GHz from RF_{in} to RF port; 4) Maximum input power; 5) Control Interface; 6) Please visit www.infineon.com/rfswitches for alternative devices.

2.3.2 Ultra-High Linearity Switches

The high-power handling capability, ultra-high linearity, excellent insertion loss and high isolation performance of the BGS1xPN9 product family combined with a tiny package size meet the most stringent linearity requirements of GSM/LTE/CDMA handset and data-card switching applications. The linearity performance achieved by these devices makes them well-suited for use in Simultaneous Voice and LTE (SV-LTE), WCDMA, CDMA and carrier aggregation applications. The devices can also be used in a variety of other applications that require high-power RF switching.

Ultra-High Linearity Switches

Product	Type	App. Note	V _{dd} [V]	V _{ctrl} ¹⁾ [V]	IL ²⁾ [dB]	Iso. ³⁾ [dB]	P _{in,max} ⁴⁾ [dBm]	Ctrl. Int. ⁵⁾	Package
BGS12PL6	SPDT	AN319	2.4...3.6	1.4 – V _{dd}	0.36 / 0.46	37 / 27	+36	GPIO	TSLP-6-4
BGS12PN9	SPDT	on request	1.8 – 3.3	1.35...V _{dd}	0.3 / 0.34	38 / 30	+35	GPIO	TSNP-9-2
BGS13PN9	SP3T	on request	1.8 – 3.3	1.35...V _{dd}	0.34 / 0.38	35 / 28	+35	GPIO	TSNP-9-2

Notes: 1) Digital Control Voltage (logic high); 2) IL = Insertion Loss at 1.0/2.0 GHz; 3) Isolation at 1.0/2.0 GHz from RF_{in} to RF port; 4) Maximum input power; 5) Control Interface; 6) Please visit www.infineon.com/rfswitches for alternative devices.

2.3.3 Diversity Antenna Switches

The recent trend of smartphone and tablet users to download more and more data anytime and anywhere increases the demand for more bandwidth and for an additional receiver channel called the diversity path. To select the right receive band, a diversity switch with low insertion loss and excellent RF performance is one method of choice. Nowadays, diversity switches covering up to 7 or more different UMTS/LTE bands are becoming more and more popular in smartphones and tablets.

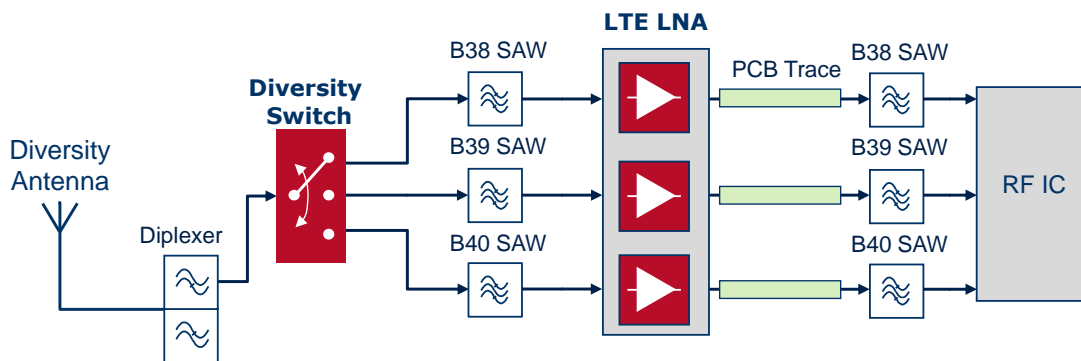

Example of TD-LTE band for diversity path

RF CMOS Switches for Diversity Antenna

Product	Type	App. Note	V _{dd} [V]	V _{ctrl} ¹⁾ [V]	IL ²⁾ [dB]	Isolation ³⁾ [dB]	P _{in,max} ⁴⁾ [dBm]	Ctrl. ⁵⁾ Int.	Package
BGS12AL7-4	SPDT	AN175 AN206	2.4...3.6	1.4...V _{dd}	0.4/0.5	32/25	21	GPIO	TSLP-7-6
BGS12AL7-6	SPDT	AN175	2.4...3.6	1.4...V _{dd}	0.4/0.5	32/25	21	GPIO	TSLP-7-6
BGS12SN6	SPDT	AN332	1.8...3.5	1.35...V _{dd}	0.25 / 0.28	40 / 32	30	GPIO	TSNP-6-2
BGS14AN16	SP4T	AN331	2.85...4.7	1.5...V _{dd}	0.34 / 0.55	40 / 30	30	GPIO	TSNP-16-6
BGS15AN16	SP5T	AN230 AN259	2.85...4.7	1.5...V _{dd}	0.34 / 0.55	40 / 30	32	GPIO	TSNP-16-6
BGS16MN14	SP6T	AN368	2.5...5.5	MIPI	0.3 / 0.4	42 / 37	32	RFFE MIPI	TSNP-14
BGS18MN14	SP8T	AN366	2.5...5.5	MIPI	0.3 / 0.5	40 / 32	32	RFFE MIPI	TSNP-14-3
BGS110MN20	SP10T	AN333	2.5...5.5	MIPI	0.4	37	32	RFFE MIPI	TSNP-20-1

Notes: 1) Digital Control Voltage (logic high); 2) IL = Insertion Loss at 1.0/ 2.0 GHz; 3) Isolation at 1.0/ 2.0 GHz from RF_{in} to RF port; 4) Maximum input power; 5) Control Interface; 6) Please visit www.infineon.com/rfswitches for alternative devices.

Carrier-Aggregation-Capable RF CMOS Switches for Diversity Antenna

Product	Type	App. Note	V _{dd} [V]	V _{ctrl} ¹⁾ [V]	IL ²⁾ [dB]	Isolation ³⁾ [dB]	P _{in,max} ⁴⁾ [dBm]	Ctrl. ⁵⁾ Int.	Package
BGS15MA12	SP5T	on request	2.2...5.5	MIPI interface	0.28 / 0.35	34 / 27	27	RFFE MIPI	aTSLP-12-4

Notes: 1) Digital Control Voltage (logic high); 2) IL = Insertion Loss at 1.0/ 2.0 GHz; 3) Isolation at 1.0/ 2.0 GHz from RF_{in} to RF port; 4) Maximum input power; 5) Control Interface; 6) Please visit www.infineon.com/rfswitches for alternative devices.

2.3.4 Band-selection Switches in a Single-ended Configuration

The number of LTE bands to support in a mobile phone is increasing rapidly worldwide. A simple way to support more bands in a mobile phone is to implement the band selection function by adding a RF CMOS switch to the existing transceiver/diversity Integrated Circuits (ICs). The following two examples show band selection with a SPDT switch in a single-ended configuration.

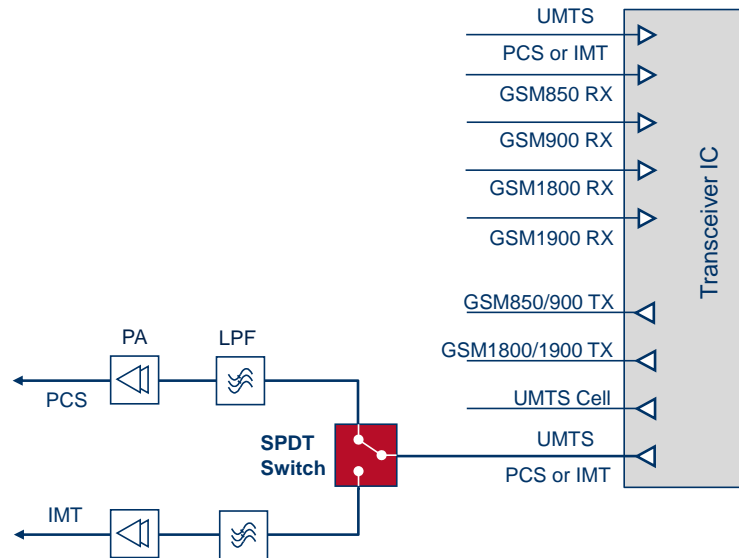

Application 1: PCS/IMT band switching with CMOS SPDT switch

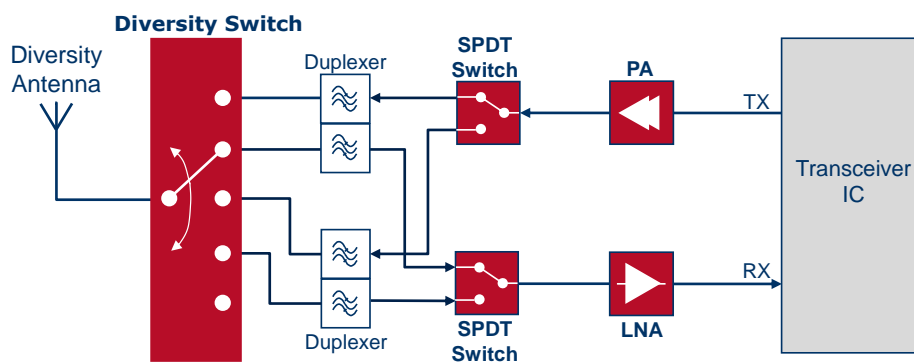

Application 2: LTE Band-1/Band-4 switching with CMOS SPDT switch

RF CMOS Switches

Product	Type	App. Note	V _{dd} [V]	V _{ctrl} ¹⁾ [V]	IL ²⁾ [dB]	Isolation ³⁾ [dB]	P _{in,max} ⁴⁾ [dBm]	Ctrl. Int. ⁵⁾	Package
BGS12AL7-4	SPDT	AN175	2.4...3.6	1.4...3.6	0.4 / 0.5	32 / 25	21	GPIO	TSLP-7-4
BGS12AL7-6	SPDT		2.4...3.6	1.4...3.6	0.4 / 0.5	32 / 25	21	GPIO	TSLP-7-6
BGS12PL6	SPDT	AN319	2.4...3.6	1.4 - V _{dd}	0.36 / 0.46	37 / 27	36	GPIO	TSLP-6-4
BGS12SN6	SPDT	AN332	1.8...3.3	1.35... V _{dd}	0.25 / 0.28	40 / 28	30	GPIO	TSNP-6-2

Notes: 1) Digital Control Voltage (logic high); 2) IL = Insertion Loss at 1.0/ 2.0 GHz; 3) Isolation at 1.0/ 2.0 GHz from RF_{in} to RF port; 4) Maximum input power; 5) Control Interface; 6) Please visit www.infineon.com/rfswitches for alternative devices.

2.3.5 Cross Switches

The following figure shows a typical application for a cross switch in a mobile phone. With this device you can always select the best performing antenna for optimizing transmit power for an up-link (UL) or improved receive sensitivity for a down link (DL).

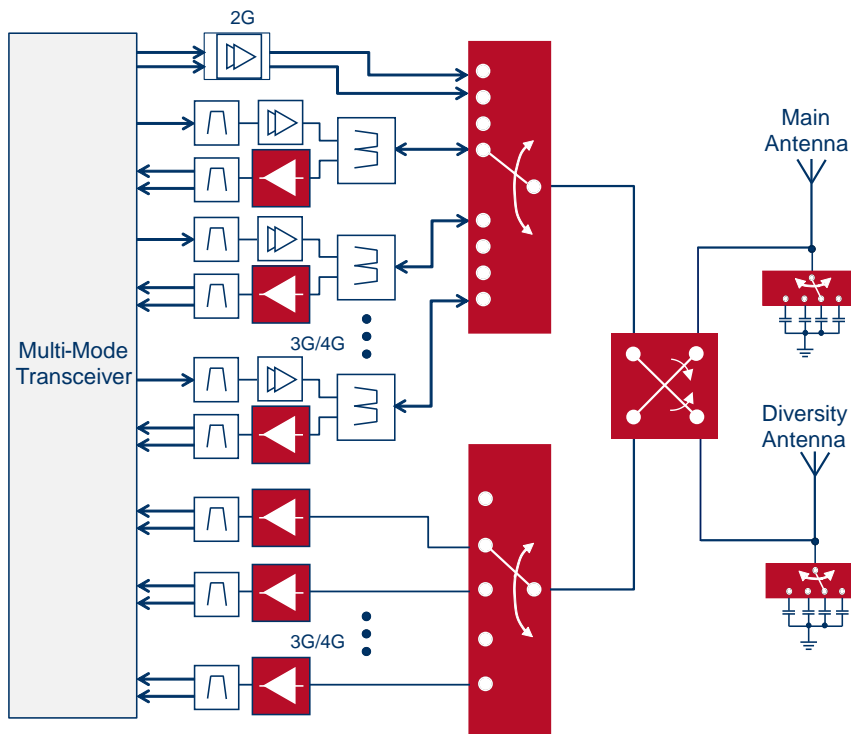

Example of cross switches

Cross Switches for Antenna Selection

Product	Type	App. Note	Supply V_{DD} [V]	$V_{ctrl}^{1)}$ [V]	$IL^{2)}$ [dB]	Isolation ³⁾ [dB]	$P_{in,max}^{5)}$ [dBm]	Ctrl. Int. ⁶⁾	Package
BGSX22GN10	DPDXT	on request	1.8 – 3.3	1.35... V_{DD}	0.35 / 0.5	25 / 22	36	GPIO	TSNP-10-1

Notes: 1) Digital Control Voltage (logic high); 2) IL = Insertion Loss at 1.0/2.0 GHz; 3) Isolation at 1.0/2.0 GHz; 4) 0.1 dB compression point; 5) Maximum input power; 6) Control Interface; 7) Please contact your local Infineon or sales representatives for further products.

2.3.6 Band-selection Switches in a Differential Configuration

The following figure shows the transceiver with differential inputs of the band-selection function with a DPDT switch in a differential configuration.

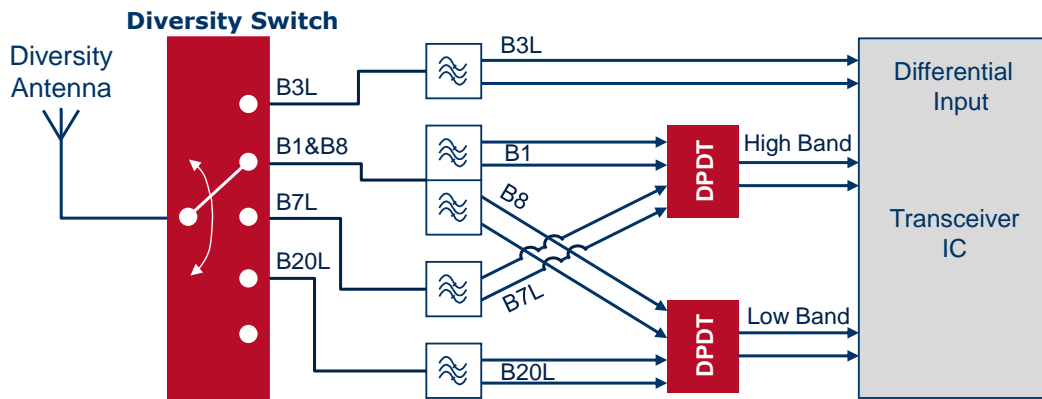

Example of band-selection switches in a differential configuration

RF CMOS DPDT Switches

Product	Type	App. Note	Supply [V]	$V_{ctrl}^{1)}$ [V]	$IL^{2)}$ [dB]	Isolation ³⁾ [dB]	$P_{in,max}^{4)}$ [dBm]	Ctrl. ⁵⁾ Int.	Package
BGS22WL10	DPDT	AN302	2.4...3.6	1.2... V_{DD}	0.33/0.39	38/28	30	GPIO	TSLP-10-1
BGS22W2L10	DPDT	AN308	2.4...3.6	1.2... V_{DD}	0.22/0.39	35/27	24	GPIO	TSLP-10-1

Notes: 1) Digital Control Voltage (logic high); 2) IL = Insertion Loss at 1.0/ 2.0 GHz; 3) Isolation at 1.0/ 2.0 GHz from RF_{in} to RF port; 4) Maximum input power; 5) Control Interface; 6) Please visit www.infineon.com/rfswitches for alternative devices.

2.4 Antenna Tuning Switches

With a global increase for data transfer rate requirements in mobile communications, the need for higher bandwidth is ever increasing. To counter this need, more and more frequency bands are being defined by the 3rd Generation Partnership Project (3GPP) consortium. Consequently, the LTE-Advanced standard specifies 44 LTE frequency bands which can be used to transfer mobile signals. Due to these stringent requirements, a mobile phone antenna should be able to achieve good performance in several frequency bands. Hence there is a growing need to tune an antenna according to the selected frequency band. This is where antenna tuning concept gains importance. In addition, antenna tuning improves antenna radiation efficiency as well as the Total Radiated Power (TRP). This reduces the stress on the antenna driving hardware on the transmitter side and increases sensitivity on the receiver side. Antenna tuning devices based on Infineon's CMOS switch technology in mobile phones allow the use of smaller antennas and/or broader frequency range. There are two types of antenna tuning: antenna aperture tuning and antenna impedance matching.

2.4.1 Antenna Impedance Matching

Antenna impedance matching is carried out at the antenna feed point as shown in the figure below. Using this type of antenna tuning, forward power to the antenna can be optimized by matching the antenna input impedance to 50 ohms. This improves antenna performance by optimizing forward power to the antenna, but has no effect on the antenna characteristics (resonant frequency and radiation efficiency). Hence this type of antenna tuning is generally not preferred.

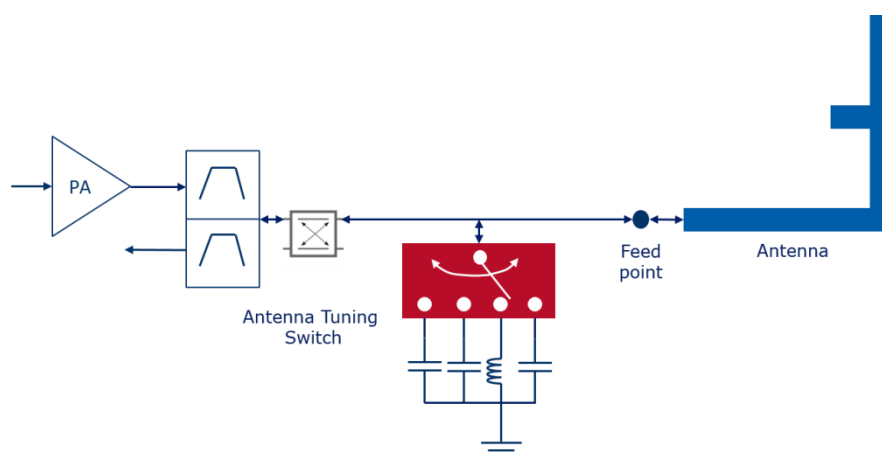

Antenna impedance matching

2.4.2 Antenna Aperture Tuning

More widely used antenna tuning technique is antenna aperture tuning. This type of antenna tuning effectively changes the characteristics of the antenna and in-turn improves antenna radiation efficiency and the Total Radiated Power (TRP). Hence this kind of antenna tuning is key focus of Infineon and is shown in the figure below.

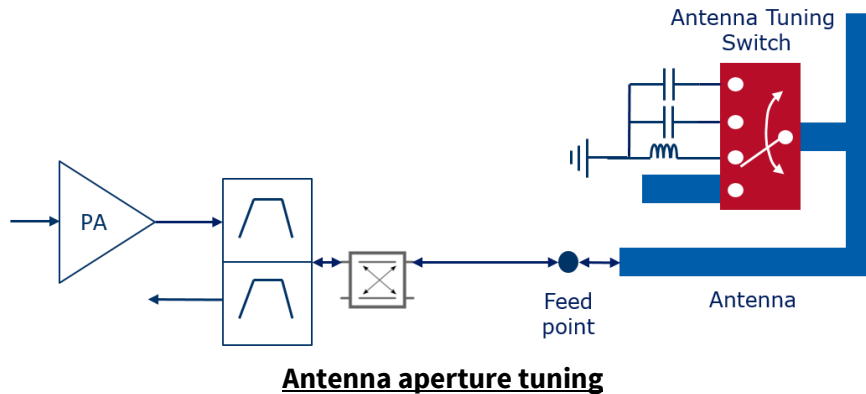

2.4.3 System Approach to Aperture Tuning

At Infineon, complete antenna-tuning solutions are provided to the customers, using our antenna-tuning switches. There are two approaches that are used for antenna tuning. The more common approach is to use antenna S-parameters. Another more recently introduced approach uses antenna dimensions to tune the antenna. These approaches are explained in the following sections in detail. There are two ports on a standard mobile phone Planar Inverted F antenna (PIFA), namely the *Feed port* and the *Tuning port* as shown in the figure below. The antenna-tuning switch with matching elements (capacitor/inductor) is placed on the tuning port of the antenna.

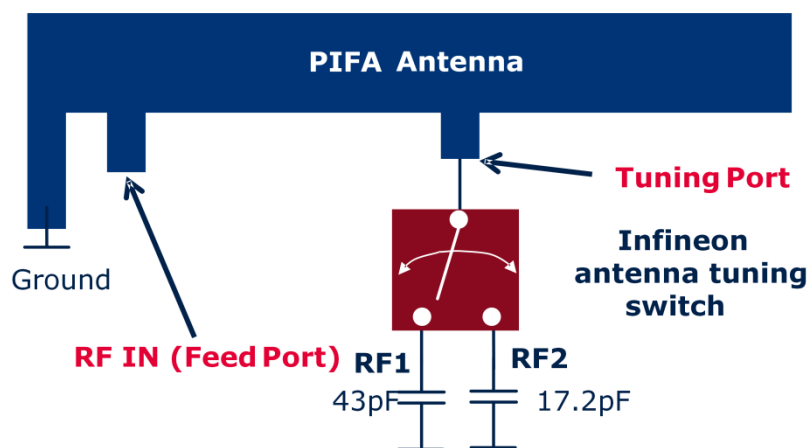

System diagram for antenna aperture tuning

Aperture tuning using antenna S-parameters

In this approach, the two port antenna S-parameters are used to tune the PIFA antenna. The S-parameters are measured and then imported into the circuit simulator. Using these S-parameters, the tuning circuit is created as shown in the circuit diagram below.

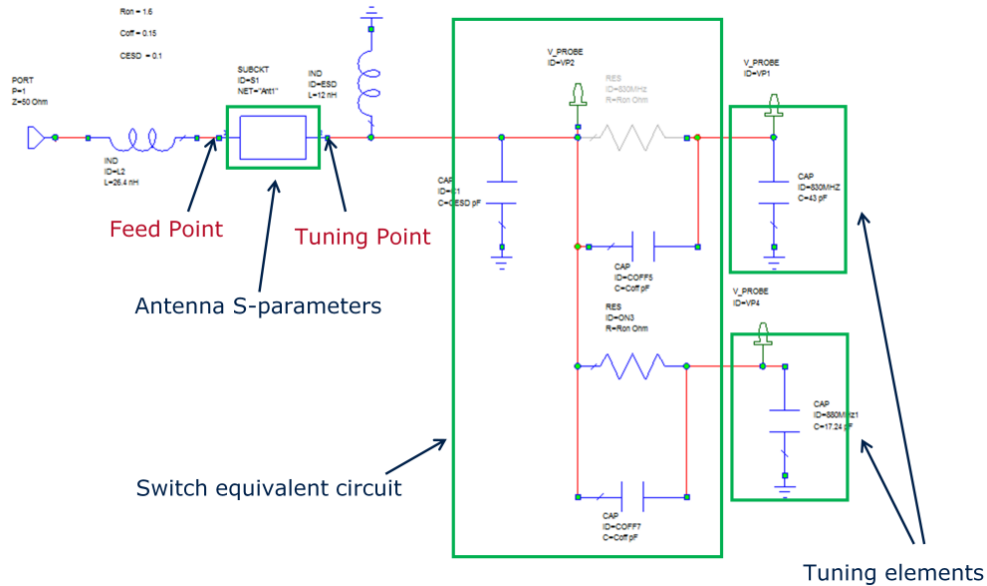

Aperture tuning using antenna dimensions

In this approach the customer provides the antenna dimensions. The antenna layout is created and simulated using a 3D Electro-Magnetic (EM) simulator. S-parameters are then extracted and the antenna-tuning circuit is created using the same approach that was described in the previous section. The only major difference between this approach and the previous approach is that here, the antenna S-parameters are extracted from the EM simulations and circuit elements are co-simulated with the EM simulation as shown below.

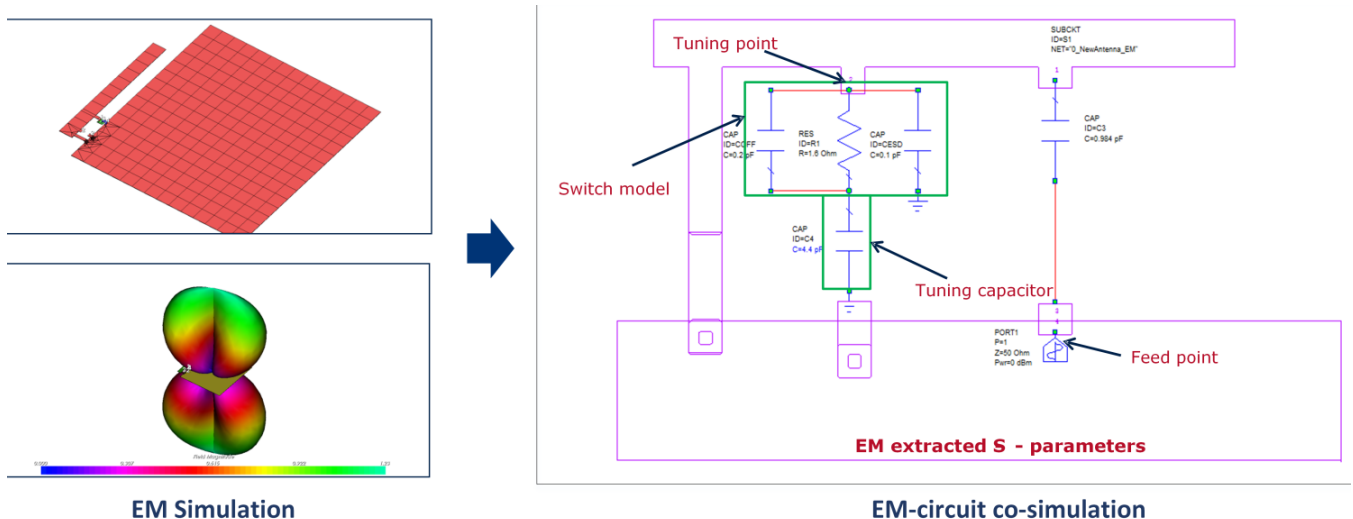

2.4.4 Key Parameters of Antenna Tuning Switches

Since antenna-tuning switches are a modified version of standard switches, the basic design challenges of standard switches apply to antenna-tuning switches as well. In addition there are some special characteristics that are important for mobile phone antenna tuning. These are explained in this section.

On Resistance (R_{ON})

The R_{ON} of an antenna-tuning switch is one of its main differentiating features. The lower the R_{ON} is, the better the switch performs. As an antenna-tuning switch is directly connected to the antenna, higher R_{ON} means higher loss and lower quality factor (Q-factor). Infineon's antenna-tuning switches have very low R_{ON} , ranging from 0.4 ohm to 1.6 ohm in each RF port.

Off Capacitance (C_{OFF})

C_{OFF} is also one of the key features of an antenna-tuning switch. A higher C_{OFF} results in a large high-frequency band loss and also results in self-resonances. Thus for better performance, a lower C_{OFF} is important for an antenna-tuning switch. Infineon's antenna tuning switches have a very low C_{OFF} , in the range of 120 fF – 200 fF.

Maximum RF Voltage (V_{RF})

Depending on the antenna design, the impedance of the antenna varies with frequency. High impedance of the antenna results in a high V_{RF} across the antenna-tuning switch. Generally, the voltage generated is much higher than the specified V_{RF} for a standard switch. Hence Infineon's antenna-tuning switches have higher V_{RF} handling capacity to cater to the special requirements for antenna tuning. Infineon's antenna-tuning switches are therefore rated up to 36 V to handle such high-stress conditions.

RF CMOS Switches for Antenna Tuning

Product	Type	App. Note	Supply [V]	$V_{ctrl}^{1)}$ [V]	$IL^{2)}$ [dB]	Isolation ³⁾ [dB]	$R_{on}^{4)}$ [Ω]	$C_{OFF}^{5)}$ [fF]	$P_{in,max}^{6)}$ [dBm]	Package
BGSA11GN10	Dual SPST	on request	1.8...3.6	0...2.85	0.16/0.25	23/17	0.79	250	39	TSNP10-1
BGSA12GN10	SPDT	on request	1.8...3.6	0...2.85	0.25/0.32	30/23	1.6	120	39	TSNP10-1
BGSA13GN10	SP3T	on request	1.8...3.6	0...2.85	0.2...0.8/0.29...0.44	26/20	0.8/1.4/1.6	300/160/120	39	TSNP10-1
BGSA14GN10	SP4T	on request	1.8...3.6	0...2.85	0.26/0.37	31/25	1.6	120	39	TSNP10-1

Notes: 1) Digital Control Voltage; 2) IL = Insertion Loss at 1.0 / 2.0 GHz (depending on RF Port); 3) Isolation at 1.0 / 2.0 GHz;
4) In ON state (RF1 / RF2 / RF3); 5) In OFF state (RF1 / RF2 / RF3); 6) Maximum input power;
7) Please visit www.infineon.com/rfswitches for alternative devices.

2.5 PIN Diode Switches

An alternative device compared to CMOS or GaAs switch is the high-performance PIN diode available from Infineon Technologies. For less complex RF circuits such as triple- and quad-band GSM/EDGE phones, PIN diodes are a good choice. PIN diodes can be used for switching in mobile phones if there is a requirement for much lower IMD generation. The following sections describe some switch solutions based on Infineon's PIN-switch diodes for cost-effective phones or base stations.

Low-barrier Schottky power-detection diodes are used for precise output power control after the power amplifier. This helps the transceiver IC to monitor the correct information about any mismatches between the mobile phone antenna and the environment, and to adjust the signal power accordingly.

Key Features of PIN Diodes:

Insertion Loss (IL) and Isolation

IL is dependent on the low impedance state of the diode in forward bias. Isolation is a measure of the PIN diode switch's performance in its open state. In a series diode switch, this is primarily dependent on the junction capacitance. These parameters are determined by the forward bias current and reverse voltage. Infineon's diodes have low capacitance and low resistance which are optimized for applications where ultra-low resistance is required.

Switching Time

The carrier life time in a PIN diode dominates the switching speed, i.e., the time required to switch the diode from a low-impedance forward bias state to a high-impedance reverse bias state.

2.5.1 Antenna Switch with PIN Diodes and Power Detection with Schottky Diodes

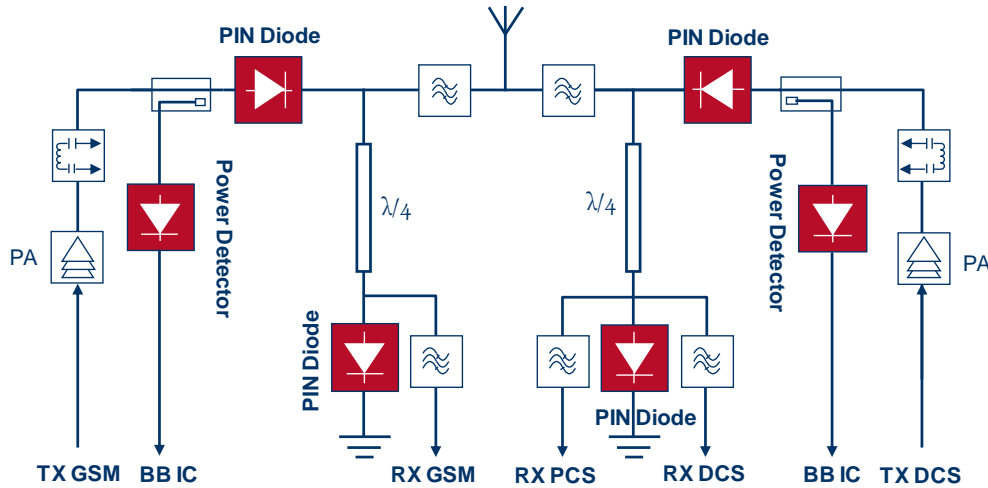

RF PIN Diode Switches

Product ¹⁾	Application Note	$r_f^{(2)}$ [Ω]	@ I_f [mA]	$r_f^{(2)}$ [Ω]	@ f [MHz]	$C_f^{(3)}$ [pF]	@ V_R [V]	$CC_L^{(4)}$ [ns]	Package
BAR90-02EL BAR90-02ELS	TR146 AN197	1.3	3.0	0.8	10.0	0.25	1.0	750	TSLP-2-19 TSSLP-2-3
BAR64-02EL	AN058	12.5	1	2.1	10	0.23	20	1550	TSLP-2-19
BAR64-04 BAR64-05 BAR64-06	AN058	12.5	1	2.1	10	0.23	20	1550	SOT23
BAR64-04W BAR64-05W BAR64-06W	AN058	12.5	1	2.1	10	0.23	20	1550	SOT323

Notes: 1) D = Dual; T = Triple; Q = Quadruple; 2) at 100 MHz; 3) at 1 MHz;
4) The charge carrier life time between the forward bias of $I_f = 10$ mA and reverse bias of $I_R = 6$ or 3 mA;
5) Please visit www.infineon.com/rf-pin-diodes for alternative devices.

RF Schottky Diodes for Power Detectors

Product	Application Note	$C_f^{(1)}$ [pF]	@ V_R [V]	V_f [mV]	@ I_f [mA]	V_f [mV]	@ I_f [mA]	I_R [μ A]	@ V_R [V]	Package
BAT62-02V	AN185	0.35	0	580	2	-	-	< 10	40	SC79
BAT15-02EL BAT15-02ELS	on request	0.26	0	230	1	320	10	< 5	4	TSLP-2-19 TSSLP-2-3

Notes: 1) at 1 MHz;
2) Please visit www.infineon.com/rf-mixer-detector-schottky-diodes for alternative devices.

2.5.2 Ultra-Low-Harmonic-Generation Band Switch with PIN Diodes

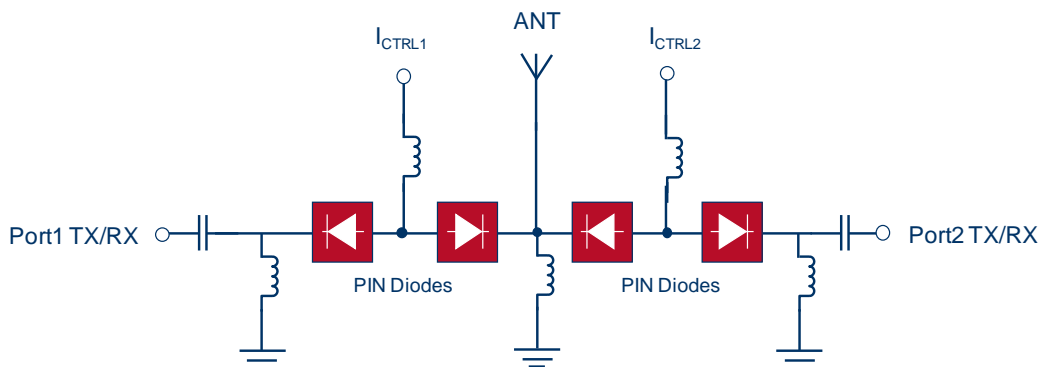

RF PIN Diode Switches

Product ¹⁾	Application Note	$r_f^{(2)}$ [Ω]	@ f [mA]	$r_f^{(2)}$ [Ω]	@ f [mA]	$C_T^{(3)}$ [pF]	@ V_R [V]	$CC^{(4)}$ [ns]	Package
BAR64-02EL	AN058	12.5	1	2.1	10	0.23	20	1550	TSLP-2-19
BAR64-04 BAR64-05 BAR64-06	AN058	12.5	1	2.1	10	0.23	20	1550	SOT23
BAR64-04W BAR64-05W BAR64-06W	AN058	12.5	1	2.1	10	0.23	20	1550	SOT323

Notes: 1) D = Dual; T = Triple; Q = Quadruple; 2) at 100 MHz; 3) at 1 MHz;
 4) The charge carrier life time between the forward bias of $I_f = 10$ mA and reverse bias of $I_R = 6$ or 3 mA;
 5) Please visit www.infineon.com/rf-pin-diodes for alternative devices.

2.5.3 Antenna Switching with PIN Diodes (I)

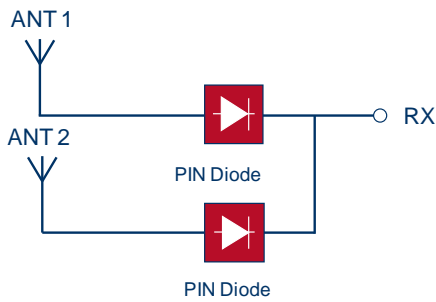

Antenna selection

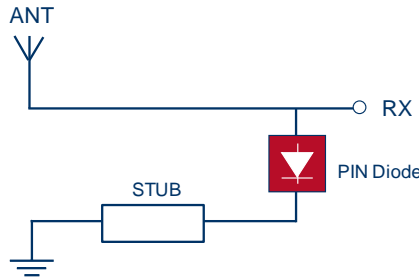

Antenna effective length modification

2.5.4 Antenna Tuning with PIN Diodes (II)

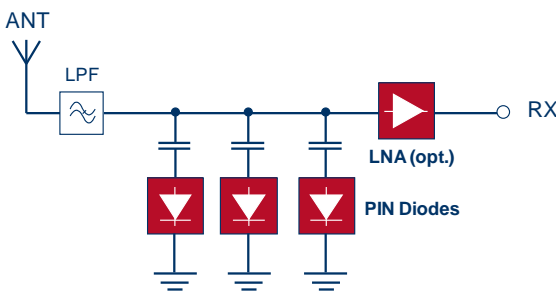

Tunable antenna with moderate IMD generation

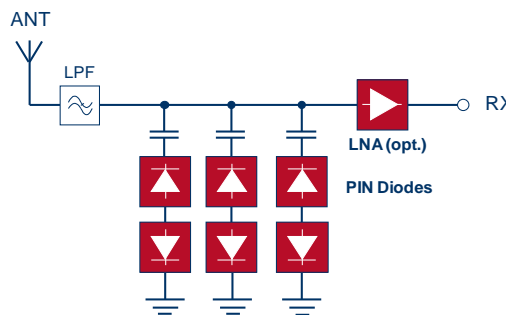

Tunable antenna with low IMD generation

2.5.5 Bypass Path for Low Noise Amplifiers

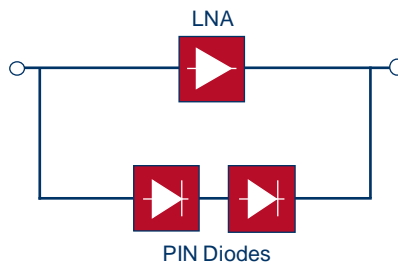

RF PIN Diode Switches

Product ¹⁾	Application Note	$r_f^{2)}$ [Ω]	@ f_c [mA]	$r_f^{2)}$ [Ω]	@ f_c [mA]	$C_f^{3)}$ [pF]	@ V_R [V]	$CC_f^{4)}$ [ns]	Package
BAR90-02EL BAR90-02ELS	TR146 AN197	1.3	3.0	0.8	10.0	0.25	1.0	750	TSLP-2-19 TSSLP-2-3

Notes: 1) D = Dual; T = Triple; Q = Quadruple; 2) at 100 MHz; 3) at 1 MHz;
 4) The charge carrier life time between the forward bias of $I_f = 10$ mA and reverse bias of $I_R = 6$ or 3 mA;
 5) Please visit www.infineon.com/rf-pin-diodes for alternative devices.

3 High-sensitivity Mobile RF Front-End with Low Noise Amplifiers

Infineon Technologies is one of the leading companies for Low Noise Amplifiers (LNAs) with broad product portfolio. The LNAs and LNA banks are based on Infineon’s Silicon Germanium Carbon (SiGe:C) bipolar technology and include built-in Electro-Static Discharge (ESD) protection of 2kV Human Body Model (HBM) even at the input pins.

A block diagram of a 2G (Global System for Mobile Communication (GSM)/ Enhanced Data Rates for GSM Evolution (EDGE)) and 3G/4G modem (Universal Mobile Telecommunications System (UMTS)/ Long-Term Evolution (LTE)) for a smartphone Radio Frequency (RF) Front-End (FE) is shown below. It consists of a broadband antenna, a band-selecting antenna switch, 3G/4G duplexers, high/low band power amplifiers, Surface Acoustic Wave (SAW) filters and 3G/4G LNAs. The LNAs are located in the diversity and main antenna paths of the phone, and they can increase data rates, for example, by doubled data rate compared to solutions without LNAs under very weak signal strength environment. High linearity assures optimal signal reception even with poorly isolated antennas and long line losses between antennas and transceivers.

Infineon’s Monolithic Microwave Integrated Circuit (MMIC) LNAs and LNA banks with their excellent low noise figure enhance the sensitivity of the RF modem by about 3 dB and offer system layout flexibility by suppressing noise contribution from losses of signal lines and from the SAW filters as well as the receiver.

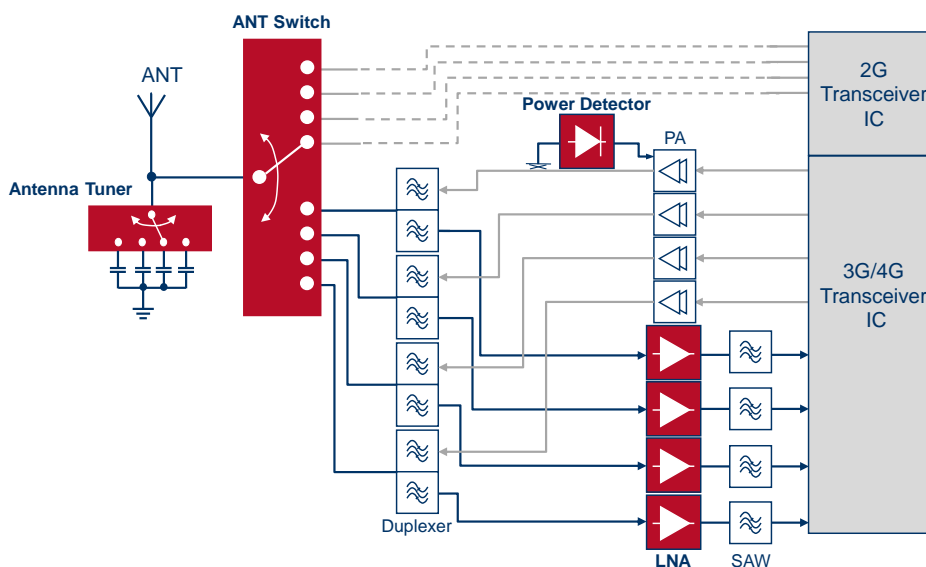

Block diagram of a 2G/3G/4G modem

With the improved system noise figure on the receive path, Infineon's new LTE LNAs can almost double smartphone data rates and improve the user experience. The product family consists of single-band LNA BGA7x1N6 and quad-band LNA Banks BGM7xxxx4L12 families. These products have ultra-low Noise Figure (NF), the exact gain and high linearity needed to help smartphone designers to overcome the challenges of LTE or 4G.

There are three single-band LTE LNAs and six quad-band LNA bank families to address the required band configurations required for different world regions. Each letter in the series name denotes a different frequency band: L for low-band (0.7 GHz to 1.0 GHz); M for mid-band (1.7 GHz to 2.2 GHz); and H for high-band (2.3 GHz to 2.7 GHz). For example, BGM7MLLM4L12 stands for a device that has two low-band LNAs (LNA 2 and LNA3), and two integrated mid-band LNAs (LNA 1 and LNA 4). They are shipped in RoHS-compliant TSNP-6-2 or TSLP-12-4 plastic packages.

The previous generation of the single-band LNA BGA7x1N7 and multiple-band LNA families, BGA735N16 and BGA748N16, have the bypass function to switch the gain of the LNA from 15 dB to about -7 dB. It helps the RF designers to implement RF FEs with more dynamic range in the input signal.

Please visit www.infineon.com/rfmmic for more details on LNA solutions for mobile phone applications, or contact your local Infineon representative.

3.1 Key Challenges of LNAs in Mobile Applications

Motivated by increasing demand for mobile broadband services with higher data rates and better quality of service, modern mobile technology has seen tremendous growth in recent years from 2G to 3G/3.5G High-Speed Packet Access (HSPA), Evolved High-Speed Packet Access (HSPA+), 3.9G LTE and recently 4G LTE-Advanced. LTE-Advanced can support data rates of up to 1 Gbps. Such higher requirements are met by using advanced Multiple Input Multiple Output (MIMO) techniques and wider bandwidths up to 100 MHz enabled by Carrier Aggregation (CA). LTE-Advanced can support up to 5 bands of carrier aggregation by three component carrier aggregation scenarios: Intra-band contiguous, intra-band non-contiguous and inter-band non-contiguous aggregation. They present new challenges to RF FE designers, such as interference from co-existing bands and harmonic generation. Smart LTE LNAs with the following features can address these requirements to achieve outstanding performance.

Low Noise Figure (NF): An external LNA or LNA module boosts the sensitivity of the system by reducing the overall NF. In addition due to the size constraint, the modem antenna and the receiver FE cannot always be placed close to the transceiver Integrated Circuit (IC). The path loss in front of the integrated LNA on the transceiver IC increases the system NF significantly. An external LNA physically close to the antenna can help to eliminate the path loss and reduce the system NF. The sensitivity can be improved by several dB, which means a significant increase in the connectivity range.

High Linearity (1-dB compression point P_{1dB} and 3rd-order intercept point IP_3): An increased number of bands at the receiver input creates strong interference, leading to high requirements in linearity characteristics such as high input 1-dB compression point, 2nd intermodulation (IMD2) products and input IP_3 performance.

Low Power Consumption: Power consumption is even more important in today's smartphones. The latest LTE-Advanced uses enhanced MIMO techniques with up to 8 streams for downlink and 4 streams for uplink. Infineon's LNAs and LNA modules have low supply current and an integrated on/off feature that reduces power consumption and increases standby time for cellular handsets or other portable battery-operated wireless applications.

High Integration and Simple Control Interface: The demand for size and cost reduction and performance enhancement with ease of use and low parts count has become very important in existing and future generation smartphones. Our MMIC LNAs are highly integrated with input and output either matched or pre-matched, built-in temperature and supply voltage stabilization, and a fully ESD-protected circuit design to ensure stable operation and a simple control interface.

3.2 Single-band LNAs and Multiple-band LNA Banks

3.2.1 Single-band LNAs

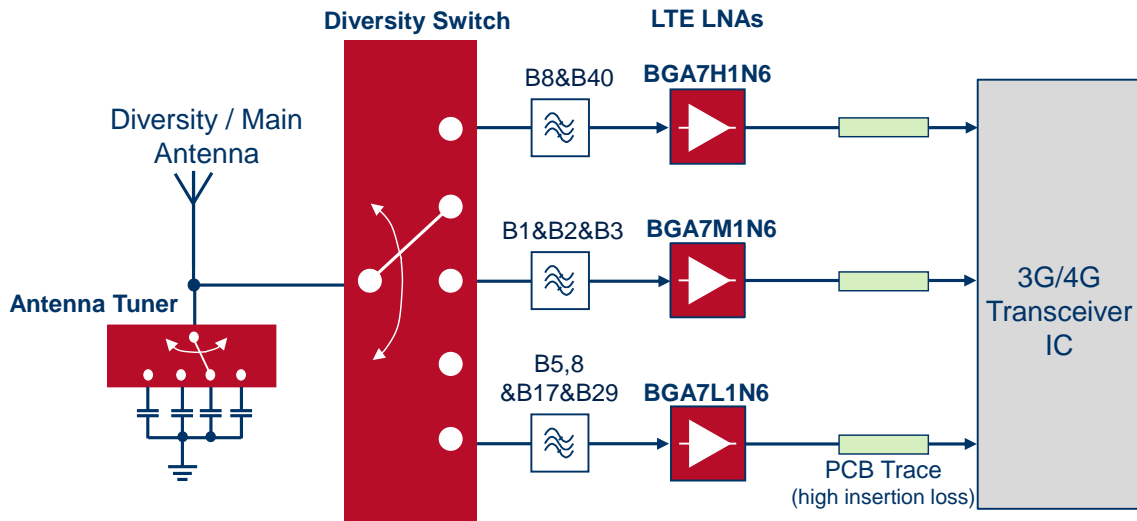

Three Single-band LNAs implemented in the diversity path

Single-band LTE-A MMIC LNAs

Product	Application note	Freq. Range [MHz]	Gain [dB]	NF [dB]	IP _{1dB} [dBm]	IIP ₃ [dBm]	Supply [V]	Current [mA]	Package
BGA7L1N6	AN351 AN364 AN404	728-960	13.0	0.9	-6	-1	1.5...3.3	4.9	TSNP-6-2
BGA7M1N6	AN350 AN371 AN405	1805-2200	13.0	0.7	-3	7	1.5...3.3	4.9	TSNP-6-2
BGA7H1N6	AN349 AN365 AN406 TR1183	2300-2690	13.0	0.7	-4	6	1.5...3.3	4.9	TSNP-6-2

Notes: Please visit www.infineon.com/ltelna for alternative devices.

Single-band 3G/4G MMIC LNAs with Bypass Function

Product	Freq. Range [MHz]	Gain ²⁾ [dB]	NF ²⁾ [dB]	IP _{1dB} ²⁾ [dBm]	IIP ₃ ²⁾ [dBm]	Supply [V]	Current ²⁾ [mA]	Package
BGA6L1BN6 ¹⁾⁴⁾	700-1000	16.1/-1.8	0.6/1.8	-5/+8	+2/+23	1.5...3.3	5.6/0.09	TSNP-6-2
BGA6H1BN6 ¹⁾⁴⁾	1800-2700	14.3/-2.8	0.8/2.8	-6/+12	+3/+25	1.5...3.3	5.5/0.09	TSNP-6-2
BGA713N7 ¹⁾	700-800	15.3/-9.9	1.1/9.9	-7/-12	-8/-2	2.8	4.8/0.5	TSNP-7-1
BGA751N7 ¹⁾	700-1100	16/-8	1.05/9.9	-6/-10	-8/-1	2.8	4.8/0.5	TSNP-7-1
BGA711N7 ¹⁾	1800-2650	17.0/-8	1.1/8.0	-8/-2	-2/+7	2.8	3.6/0.5	TSNP-7-1
BGA777N7 ¹⁾	2300-2700	16.0/-7.0	1.2/6.9	-10/-2	-2/+7	2.8	4.2/0.5	TSNP-7-1

Notes: 1) LNA with two gain modes (high-gain/low-gain); 2) Values in high-gain (HG) / low-gain (LG) mode;
3) Please visit www.infineon.com/ltelna for alternative devices. 4) On request

3.2.2 Multiple-Band LNA Banks

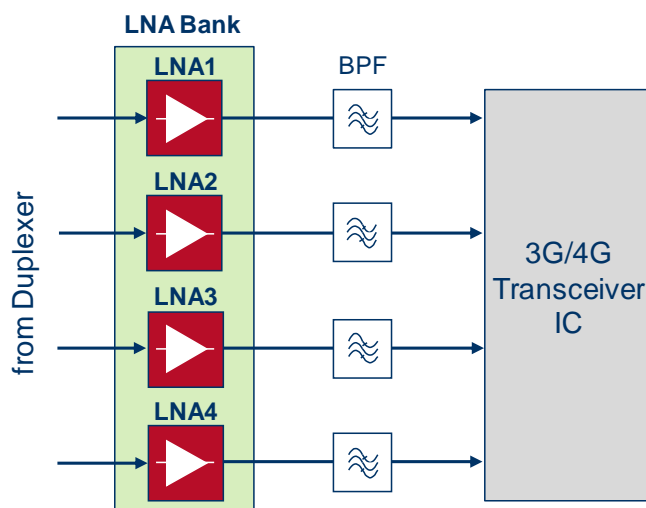

Quad-band LNA bank implemented in the main path

Quad-band LTE-A LNA Banks (Product Details on Request)

Product	Freq. Range [MHz]	Gain [dB]	NF [dB]	IP _{1dB} [dBm]	IIP ₃ [dBm]	Supply [V]	Current [mA]	Package
BGM7MLLH4L12 ¹⁾	1805-2200 728-960 728-960 2300-2690	13.0 ²⁾	0.6 ²⁾	3 ²⁾	5	1.5...3.3 ²⁾	5.0 ²⁾	TSLP-12-4
BGM7LMHM4L12 ¹⁾	728-960 1805-2200 2300-2690 1805-2200	13.0	0.8	1	8	1.5...3.3	5.5	TSLP-12-4
BGM7HHMH4L12 ¹⁾	2300-2690 2300-2690 1805-2200 2300-2690	13.0 ²⁾	0.6 ²⁾	3 ²⁾	5 ²⁾	1.5...3.3 ²⁾	5.0 ²⁾	TSLP-12-4
BGM7MLLM4L12 ¹⁾	1805-2200 728-960 728-960 1805-2200	13.0	0.7	2	9	1.5...3.3	5.5	TSLP-12-4
BGM7LLHM4L12 ¹⁾	728-960 728-960 2300-2690 1805-2200	13.0	0.7	2	8	1.5...3.3	5.5	TSLP-12-4
BGM7LLMM4L12 ¹⁾	728-960 728-960 1805-2200 1805-2200	13.0	0.7	2	5	1.5...3.3	5.0	TSLP-12-4

Notes: 1) On request;
2) Based on preliminary datasheet
3) Please visit www.infineon.com/ltelna for alternative devices;

Triple-band 3G/4G MMIC LNA Bank with Bypass Function

Product	Freq. Range [MHz]	Gain ²⁾ [dB]	NF ²⁾ [dB]	IP _{-1dB} ²⁾ [dBm]	IIP ₃ ²⁾ [dBm]	Supply [V]	Current ²⁾ [mA]	Package
BGA735N16 ¹⁾	700-1000 1450-2000 2100-2700	16.5/-7.8	1.1/7.8	-6/-10	-11/-1	2.8	3.7/0.65	TSNP-16-1

Notes: 1) LNA with two gain modes (high-gain/low-gain); 2) Values in high-gain/low-gain mode; 3) Please visit www.infineon.com/telna for alternative devices.

Quad-band 3G/4G MMIC LNA Bank with Bypass Function

Product	Freq. Range [MHz]	Gain ²⁾ [dB]	NF ²⁾ [dB]	IP _{-1dB} ²⁾ [dBm]	IIP ₃ ²⁾ [dBm]	Supply [V]	Current ²⁾ [mA]	Package
BGA748L16 ¹⁾	700-1000 700-1000 1450-2000 2100-2700	16.6/-8.0	1.1/8.0	-8/+2	-7/+15	2.8	4.0/0.75	TSNP-16-1

Notes: 1) LNA with two gain modes (high-gain/low-gain); 2) Values in high-gain/low-gain mode; 3) Please visit www.infineon.com/telna for alternative devices.

3.3 LNA Multiplexer Modules for Carrier Aggregation

Beside the single-band LNAs and quad-band LNA banks, there are three LNA Multiplexer Modules (LMMs): BGM15LA12, BGM15MA12 and BGM15HA12. Each device consists of a SP5T switch and a broadband LNA. With the five input pins the LMM can support five individual bands for single-carrier operation as well as carrier aggregation mode. Each input of BGM15LA12 can support different low-bands (0.7 GHz to 1.0 GHz); BGM15MA12 can support different mid-bands (1.7 GHz to 2.2 GHz); BGM15HA12 can support different high-bands (2.3 GHz to 2.7 GHz). All these devices are programmable using RFFE MIPI. They are shipped in Restriction of Hazardous Substances (RoHS)-compliant ATSLP-12-1,-2,-3 plastic packages.

Time-division duplexing (TDD)-mode LTE systems combined with Frequency-Division Duplexing (FDD)-mode LTE systems are steadily gaining importance. As end users continue to download more and more data anytime and anywhere, there is an increasing need for more bandwidth and an additional receiver channel called the “diversity path” in smartphones. In most current mobile phones, there is a second antenna for the diversity path. Diversity exploits the multipath propagation phenomenon of microwaves in order to enhance the reception of cellular signals. The diversity antenna is usually located far from the main antenna and the transceiver IC. The received signal therefore undergoes signal losses along the path from the diversity switch to the transceiver IC. It is necessary to use a LNA / LNA bank / LNA multiplexer module closer to the diversity switch to overcome this and enhance the sensitivity of the system. The LNAs/LNA banks/LNA multiplexer modules improve the receiver performance significantly by reducing the noise from the long route line between the diversity antenna and the transceiver IC, and compensating for the losses incurred due to the band-pass filter and NF of the transceiver.

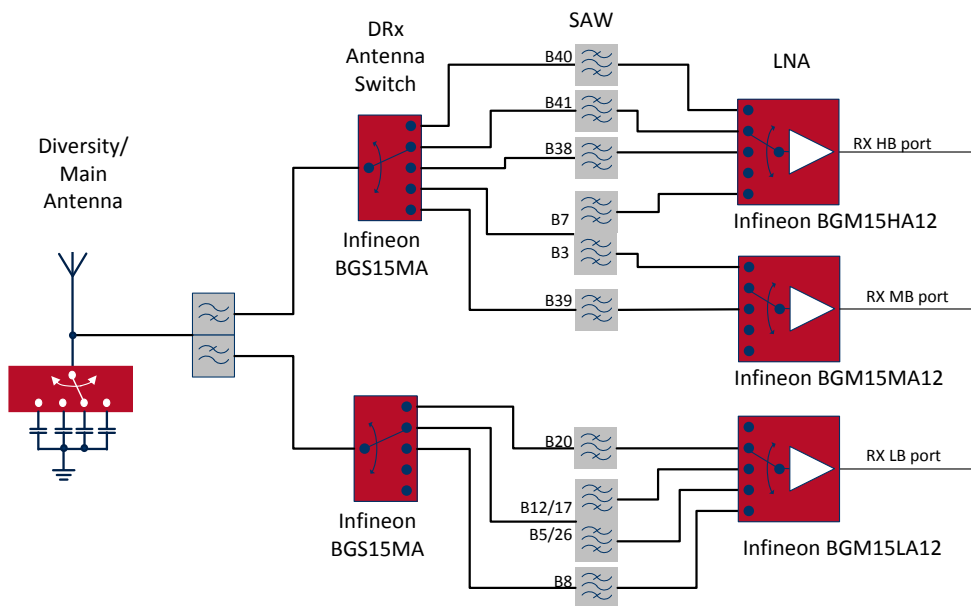

LNA multiplexer module implemented in the diversity path

LNA Multiplexer Modules for LTE-Advanced Applications

Product	Application note	Freq. Range [MHz]	Gain [dB]	NF [dB]	IP _{1dB} [dBm]	IIP ₃ [dBm]	Supply [V]	Current [mA]	Package
BGM15LA12 ¹⁾	AN373 ¹⁾	700-1000	15.0	1.1	-2.5	6.0	2.2-3.3	4.8	ATSLP-12-1
BGM15MA12 ¹⁾	AN374 ¹⁾ TR1180 ¹⁾	1700-2200	15.5	1.2	-9	6.0	2.2-3.3	4.7	ATSLP-12-2
BGM15HA12 ¹⁾	AN375 ¹⁾ TR1181 ¹⁾	2300-2700	14.4	1.2	-4	6.0	2.2-3.3	4.9	ATSLP-12-3

Notes: 1) On request; 2) Please visit www.infineon.com/ltelna for alternative devices.

3.4 LNAs for 3.5 GHz TD-LTE Modems

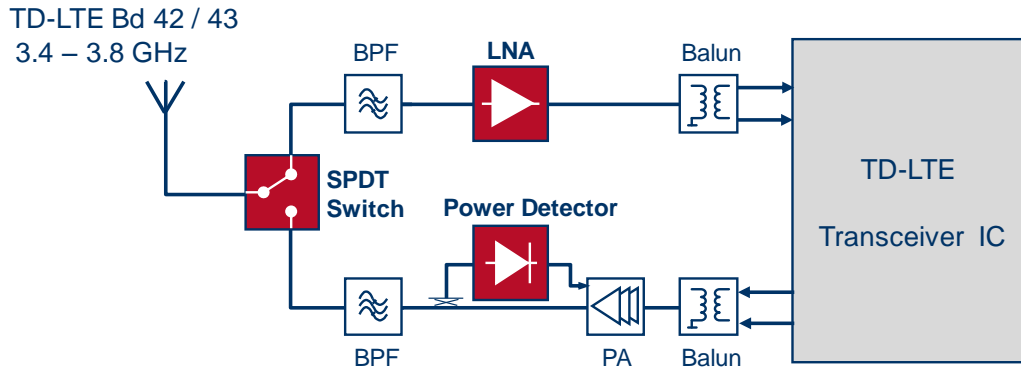

RF MMIC LNAs

Product	Application Note	Gain [dB]	NF [dB]	IP_{-1dB} [dBm]	IIP_3 [dBm]	Supply [V]	Current [mA]	Package
BGB707L7ESD	TR171	14.3	1.3	-8	-5	2.8	5.4	TSLP-7-1

Note: Please visit www.infineon.com/rf-mmhc for alternative devices.

RF Transistor LNAs

Product	Application Note	Gain [dB]	NF [dB]	IP_{-1dB} [dBm]	IIP_3 [dBm]	Supply [V]	Current [mA]	Package
BFP840FESD	TR1129	17.5	1.1	-13	-3	3.0	15	TSFP-4
BFP843F	AN315	18	1.2	-11	-3	3.0	14	TSFP-4
BFR843EL3	AN307 AN328	16	1.1	-11	-1	3.0	12	TSLP-3-9

Note: Please visit www.infineon.com/lna up to 12 GHz for alternative devices.

RF CMOS TX/RX Switches

Product	Type	App. Note	Supply [V]	$V_{ctrl}^{1)}$ [V]	$IL^{2)}$ [dB]	Isolation [dB]	$P_{0.1dB}^{3)}$ [dBm]	$P_{in,max}^{4)}$ [dBm]	Ctrl. Int. ⁵⁾	Package
BGS12PL6	SPDT	AN319	2.4...3.6	1.4...3.6	0.77	22	38	35	GPIO	TSLP-6-4

Notes: 1) Digital control voltage; 2) IL = Insertion Loss; 3) 0.1dB compression point; 4) Maximum input power; 5) Control Interface; 6) Please visit www.infineon.com/rfswitches for alternative devices.

4 Global Navigation Satellite Systems

Global Navigation Satellite Systems (GNSSs) are among the fastest growing businesses in the electronic industry. Today, GNSSs include much more than the well-known GPS (Global Positioning System), which was introduced for civilian use more than a decade ago. Nations around the world are working on their own navigation satellite systems for strategic reasons and to offer improved user experience. Today, three GNSS systems are operational: the United States GPS, the Russian GLobal Orbiting Navigation Satellite System (GLONASS), and the Chinese Beidou System. The Galileo positioning system being developed by the European Union is expected to provide initial public service by 2016 and full functionality by 2020 using 24 operational satellites for commercial applications.

From a civilian usage point, additional systems added to GNSS bring with them the advantages of increased satellite signal reception, increased coverage, higher precision, and the facility for additional features such as Search And Rescue (SAR). The most important market segments since 2008 are Personal Navigation Devices (PNDs) and GNSS-enabled mobile phones. The architecture and the performance of the Radio Frequency (RF) Front-End (FE) must be optimal in order to fulfill the strict requirements of the GNSS system. The main challenges for the growing GNSS-enabled mobile phone market are to achieve high sensitivity and high immunity defined by government regulations against interference of cellular signals for safety and emergency reasons. This means GNSS signals must be received at very low power levels (down to less than -160 dBm) in mobile phones in the vicinity of co-existing high-power cellular signals. In addition, portable and mobile phones must have excellent Electro-Static Discharge (ESD) robustness and low power consumption to ensure long battery usage time.

Infineon Technologies is the market leader in GNSS Low Noise Amplifiers (LNAs) for navigation applications in Personal Navigation Devices (PND) and cellular products. Infineon offers a complete product portfolio to all customers designing high-performance flexible RF front-end solutions for GNSSs:

- **Low Noise Amplifiers (LNAs):** Infineon offers a wide range of products such as high-performance Monolithic Microwave Integrated Circuits (MMICs) as well as cost-effective and high-end RF transistors
- **Front-End Modules (FEMs):** Infineon offers the world's smallest GNSS FEMs with LNAs and band-pass filter(s) integrated into a single tiny package with well-optimized performance for navigation features in mobile phones
- **Transient Voltage Suppression (TVS) Diodes:** Infineon devices can protect GNSS antennas reliably up to 20 kV
- **RF Switches:** Infineon switches allow for diversity architecture with active antennas

Infineon's GNSS LNA and FEM products have low Noise Figure (NF), high gain, high linearity, high levels of ESD protection, and low power consumption to satisfy the increasing requirements of GNSS systems. Infineon offers LNAs optimized for high linearity and high gain. Our latest GNSS LNA products covering all current GNSS systems include BGA924N6 and BGA824N6 with very low NF and high Out-of-Band (OoB) 3rd-order intercept point (IP3) to enhance interference immunity.

BGA925L6 and BGA825L6 are two of the smallest GNSS LNAs in the world. They have low NF and high OoB performance, and they work under extreme jamming conditions. BGA725L6 is one of the smallest GNSS LNAs with high gain and low noise.

Designed for various GNSS antenna positions in mobile phones, various GNSS FEM products are released with the following two topologies:

- **Surface Acoustic Wave (SAW)-Filter/LNA Topology:** Enables flexibility in the placement of the GNSS antenna without degrading the GNSS performance.
- **Notch Filter/SAW-Filter/LNA Topology:** With an additional integrated notch filter in front of the GNSS FEM, the GNSS is enhanced to reject mobile jammer signals, especially for LTE Band-13, to ensure GNSS reception even with weak GNSS and high jammer signal conditions.

All Infineon GNSS FEM products offer an ESD robustness higher than 6 kV at the RF input pin, tested with the IEC61000-4-2 contact discharge standard.

Please visit www.infineon.com/gnss and www.infineon.com/rf-nav.frontend for more details on products for navigation in mobile phones and portable devices, or contact your local Infineon representative.

4.1 Key Features of GNSS Front-End Components

4.1.1 Key Features of GNSS Low Noise Amplifiers (LNAs)

Low Noise Figure & High Gain

The power levels of satellite signals received by a GPS/GNSS receiver are as low as -160 dBm. Such systems must be very sensitive. An external LNA with low NF and high gain is required to boost the sensitivity of the system and Time-To-First Fix (TTFF).

High Linearity

In modern mobile phones, GNSS signals coexist with strong interfering cellular signals. The cellular signals can mix to produce intermodulation products in the GNSS receiver frequency band. To enhance interference immunity of the GNSS systems, LNAs with high linearity characteristics e.g. IP3 and P1dB are required.

Low Current Consumption

Power consumption is an important feature in many GNSS systems that are mainly battery-operated mobile devices. Infineon's LNAs have an integrated power on/off feature which provides for low power consumption and increased stand-by time for GNSS handsets. Moreover, the low current consumption (3.6 mA) makes Infineon's LNAs suitable for portable technology such as GNSS receivers and mobile phones.

4.1.2 Key Features of GNSS Surface Acoustic Wave (SAW) Filters

Low Insertion Loss

The pre-filter should not contribute to losses in the system since it is the first block after the antenna in the receiver chain. Losses in the pre-filter will impact the NF of the receiver system significantly. Infineon's SAW filters introduce an insertion loss of only 1 dB in the pass band.

High Out-of-Band Rejection

The strong cellular signals that coexist in a mobile phone can drive the GNSS LNA into saturation. These signals can be filtered out with a pre-filter and post-filter to prevent interference in later stages. The SAW filter should have high OoB rejection. Infineon's SAW filters have high OoB rejection of about 34 dB.

High Linearity Capability

It has been verified that both the LNA and the SAW filter can introduce OoB intermodulation products of mobile signals that are within the GNSS bands. Therefore it is a key requirement for a GNSS SAW filter to have high linear surface acoustic resonators, especially at the input stage resonators of the SAW filter.

4.2 System Challenges for Modern GNSS Reception in Mobile Devices

GNSS receivers for mobile or handheld devices are always at risk of strong interference from high-power cellular signals. Due to the coexistence of GNSS and cellular services, there is a strong coupling of the Digital Cellular Service (DCS)/ Personal Communications Services (PCS) and cellular (Global System for Mobile Communication (GSM)/ Code Division Multiple Access (CDMA)/3G/ Long-Term Evolution (LTE)) signals to the GPS receiver. The performance of a standard integrated GNSS receiver chip cannot meet the specifications required for modern-day systems. An external RF FE is essential to achieve this required performance. The most important prerequisites for the FE of a GNSS receiver are low NF and sufficient amplification of the desired signal together with high attenuation of the jammer signals. We need an external LNA with low NF and high gain preceded by a band-pass filter with low Insertion Loss (IL) and high OoB attenuation to achieve this.

GNSS receiver sensitivity enhancement with an external LNA

In the circuit chain of a receiver, the NF of the first stage LNA dominates the overall system NF. Consider a GNSS receiver IC with NF of 2.3 dB.

By adding Infineon's LNA [BGA824N6](#) with NF 0.6 dB and Gain 17 dB to the front of the receiver IC, the NF F_{sys} of the receiver system can be expressed by using Friis Formula:

$$F_{sys} = F_{LNA} + \frac{F_{receiver}-1}{G_{LNA}}$$

Using the above equation, $F_{sys} = 1.16$. Therefore, $NF_{sys} = 10 \log F_{sys} = 0.66$ dB.

The sensitivity of the GNSS system can thus be improved by 1.6 dB through the external LNA. The NF of the system is dominated by the NF and gain of the first stage LNA. Adding a LNA with very low NF and excellent linear performance improve the overall receiver sensitivity, which leads to low TTFF and more GNSS coverage in real field applications for the end user.

Noise Figure degradation due to high power of jammer signal

High power interfering jammer signals may leak into the GNSS receiver and affect the receiver's sensitivity by overdriving the receiver's LNA. This presents a major challenge to RF FE designers to maintain the receiver's sensitivity for weak incoming GNSS signals. It is important to use an external LNA with very good noise performance in the presence of strong interfering signals. The LNA needs to exhibit outstanding OoB P1dB performance against jammer signals so that it is not desensitized. The following figure shows the NF degradation of Infineon's LNA [BGA824N6](#) due to high-power incoming jammer signals.

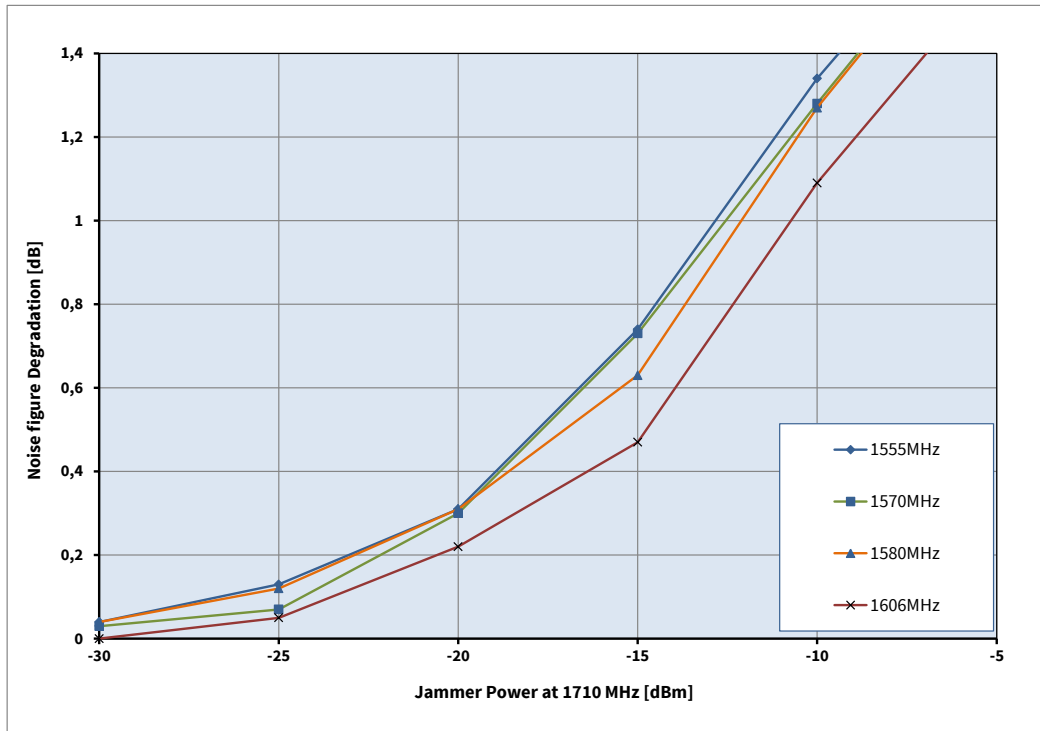

Noise figure desensitization effect caused by jammer signal

Out-of-band interference

Because GNSS and cellular systems coexist in a compact area in a mobile phone, coupling from cellular transmitter to GNSS receive path results in OoB intermixing of cellular signals in FE devices. For example, GSM 1712.7 MHz and UMTS 1850 MHz produce third-order intermodulation products at GPS frequencies. This effect desensitizes the GPS receiver and decreases its performance. OoB measurements are used to quantify this. The OoB IIP3 can be calculated as follows.

$$\text{Out-of-band Input } IP3 = P1_{IN} + [P2_{IN} - (IM3_{out_GPS} - Gain_{at\ GPS})]/2$$

The following figure demonstrates the OoB IP3 measurement.

A GSM signal of frequency $f1_{IN} = 1713$ MHz and power $P1_{IN} = -20$ dBm and UMTS signal of frequency $f2_{IN} = 1851$ MHz and power $P2_{IN} = -20$ dBm are used. The 3rd-order intermodulation product, $2 \times f1_{IN} - f2_{IN}$, is located at the GPS band.

Using the above equation, the OoB IIP3 can be calculated as

$$IIP3 = -20 + [-20 - (-64.8 - 15.8^1)]/2 = 10.3 \text{ dBm,}$$

(Note: 1) Gain at GPS is from [BGA925L6](#).)

which is well above the specified value for mobile GNSS applications, e.g. about +7 dBm.

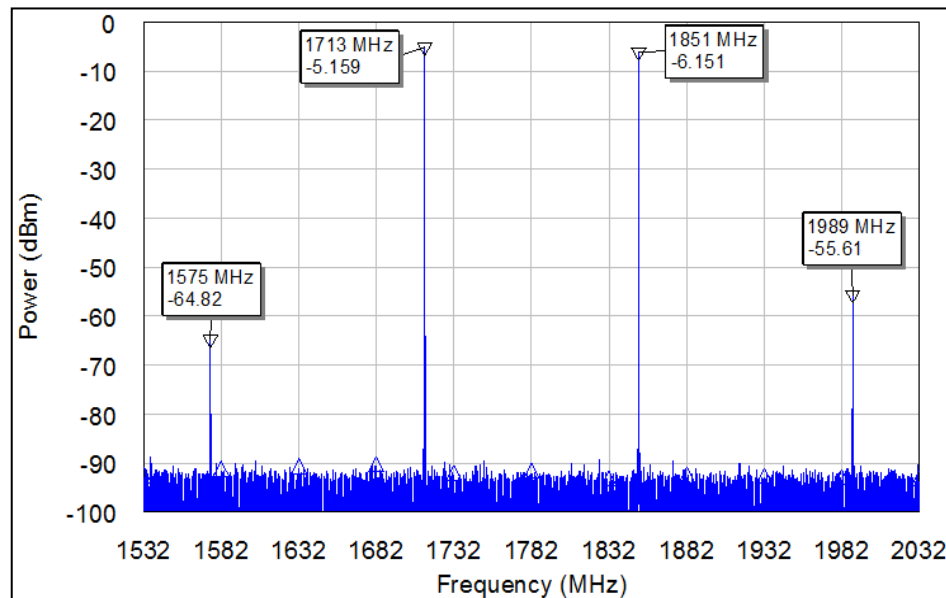

Out-of-band IIP3 measurement

LTE Band 13 interference

The 2nd harmonic of LTE band-13 (700 MHz) is located in the GNSS band at 1575 MHz. The following block diagram depicts the interference measurement of LTE band-13 with the GNSS band of 1575 MHz.

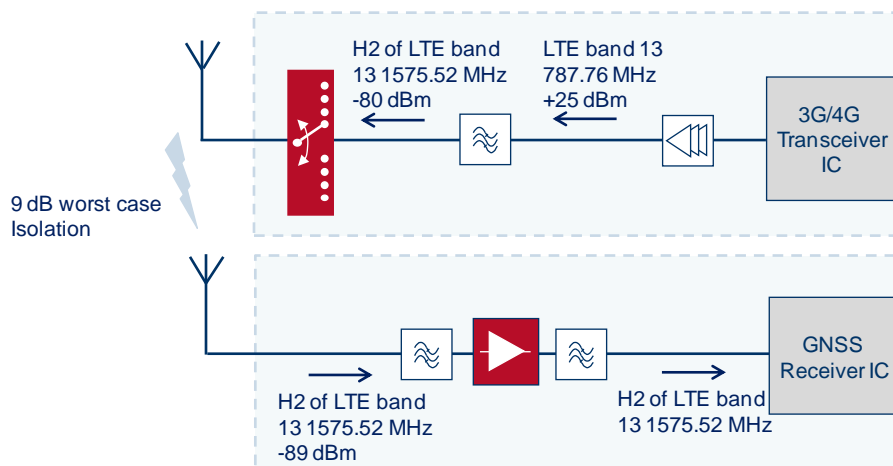

In this example, considering a worst-case isolation of 9 dB between the both antennas, jammer frequency $f_{LTE} = 787.76$ MHz, and the power of the second harmonic $f_{H2} = 1575.52$ MHz is -89 dBm at the GPS antenna.

Infineon MMICs and FEMs provide very high OoB signal rejection along with high input compression points. As an example, BGM1043N7 shows a rejection of -70 dBc. Please refer to Infineon’s application note [AN287](#) for more information.

4.3 RF Front-End Devices for GNSS

GPS: 1575.42 MHz
 GLONASS: 1598.0625 – 1609.3125 MHz
 Galileo & Beidou (北斗): 1559.052 – 1591.788 MHz

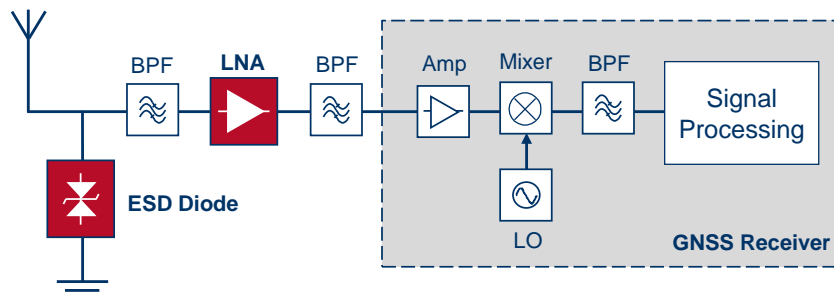

RF MMIC LNAs

Product	Application Note	Gain ¹⁾ [dB]	NF ¹⁾ [dB]	IP _{1dB} ¹⁾ [dBm]	IIP ₃ ¹⁾ [dBm]	Supply [V]	Current ¹⁾ [mA]	Package
BGA925L6	AN265	15.8	0.7	-7	1.7	1.5...3.6	5.0	TSLP-6-2
	AN266	15.5	1.0	-9	-5			
	AN267	15.6	0.8	-9	-5			
	AN274	14.5	2.0	-5	-2			
BGA825L6	AN297	17.1	0.6	-5.7	6.5	1.5...3.6	5.0	TSLP-6-3
	AN304	15.9	1.7	-5.3	-1.1		5.2	
BGA824C²⁾ BGA824N6	AN318²⁾	--	--	--	--	1.5...3.6	--	FWLP-6-1 TSNP-6-2
	AN325	17.0	0.6	-7	+2		3.9	
	AN326	15.4	2.0	-5.2	-4.9		4.1	
BGA725L6	AN334	16.4	0.9	-8.7	-7.1	1.5...3.6	4.0	TSLP-6-2
	AN280	19.9	0.7	-15	-6		3.9	
BGA524N6	AN346	19.6	0.6	-12	-8	1.5...3.6	2.5	TSNP-6-2

Notes: 1) Supply voltage at 2.8 V and frequency at 1575 MHz; 2) on request;
 3) Please visit www.infineon.com/gnss for alternative devices.

RF Transistor LNAs

Product	Application Note	Gain [dB]	NF [dB]	IP _{1dB} [dBm]	IIP ₃ [dBm]	Supply [V]	Current [mA]	Package
BFP740ESD BFP740FESD BFR740L3RH	AN120	19.7	0.8	-17	0	1.8	9.6	SOT343 TSFP-4 TSLP-3-9
BFP640ESD BFP640FESD	AN194	16.5	0.8	-16	+1	2.1	7.5	SOT343 TSFP-4
BFP640F	AN128	15.2	0.9	-13	0	2.1	8.0	TSFP-4
BFP405	AN149	15.3	1.6	-23	-5	1.8	2.6	SOT343

Note: Please visit www.infineon.com/lna up to 12 GHz for alternative devices.

TVS Diodes for Antenna ESD Protection

Product	Application	V_{RWM} [V]	ESD ¹⁾ [kV]	V_{CL} ²⁾ [V _{CL}]@[A]	R_{dyn} ³⁾ [Ω]	I_{PP} ⁴⁾ [A]	V_{CL} ⁵⁾ [V]	C_T ⁶⁾ [pF]	Protected Lines	Package
ESD108-B1-CSP0201 ESD119-B1-CSP01005	med. P _{RF} AN392	±5.5	±25	±20@±16 ±31@±30	0.76	1 2.5	8.5 11	0.25	1	WLL-2-1 WLL-2-2
ESD105-B1-02EL/02ELS	med. P _{RF}	±5.5	±25	±14@±16 ±20@±30	0.35	2 5	8.5 11	0.3	1	TSLP-2-20 TSSLP-2-4
ESD101-B1-02EL/02ELS	med. P _{RF} AN327	±5.5	±12	±18@±8 ±30@±16	1.5	-	-	0.10	1	TSLP-2-20 TSSLP-2-4
ESD103-B1-02EL/02ELS	high P _{RF} AN327	±15	±10	±36@±8 ±48@±16	1.8	-	-	0.10	1	TSLP-2-20 TSSLP-2-4

- Notes:
- 1) Electrostatic discharge as per IEC61000-4-2, contact discharge;
 - 2) TLP clamping voltage for 100 ns pulse length;
 - 3) Dynamic resistance (ON-resistance) evaluated with TLP measurement (100 ns pulse length);
 - 4) Maximum peak pulse current according to IEC61000-4-5 (8/20 μs);
 - 5) Clamping Voltage at $I_{PP,max}$ according to IEC61000-4-5 (8/20 μs);
 - 6) Typical capacitance at 1 MHz (unless specified), 0 V, I/O vs. GND;
 - 7) Please visit www.infineon.com/protection/low-cap.esd-diodes for alternative devices.

4.4 Integrated Front-End Modules for GNSS

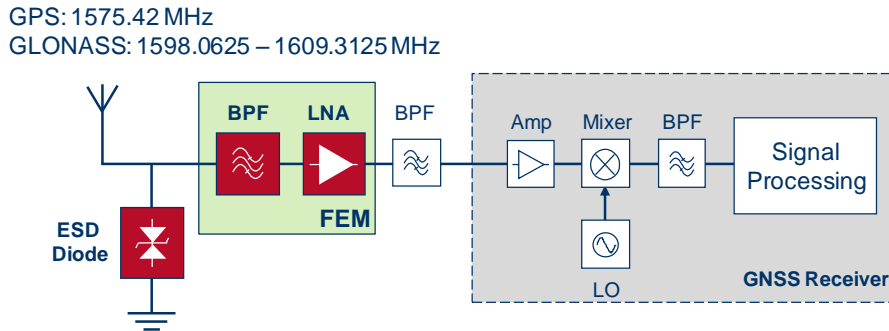

RF MMIC FEMs (DC and In-Band Parameters)

Product	Application Note	FEM Conf.	Gain ¹⁾ [dB]	NF ¹⁾ [dB]	IP _{-1dB} ¹⁾ [dBm]	IIP ₃ ¹⁾ [dBm]	Supply [V]	Current ¹⁾ [mA]
BGM1043N7	AN283	SAW+LNA	15.1	1.5	-6.3	-6.0	1.5...3.6	4.4
	AN286		14.8	1.6	-7.2	-6.4		4.1
	AN287		14.6	1.7	-6.5	-6.4		4.2
	AN294		14.8	1.6	-6.5	-5.9		4.1
BGM1034N7	AN268 AN269	SAW+LNA	17.0	1.7	-13.1	-8.7	1.5...3.6	4.2

Notes: 1) Supply voltage at 2.8 V and frequency at 1575 MHz.

RF MMIC FEMs (Out-of-Band Parameters)

Product	Application Note	Jammer signal rejection [dBc] ¹⁾			IP _{-1dB} ²⁾ [dBm]	IMD2 ³⁾ [dBm]	IIP ₃ ⁴⁾ [dBm]	Package
		900 MHz	1800 MHz	2400 MHz				
BGM1043N7	AN283	49	43	50	31/33	-50	63	TSSNP-7-10
	AN286	49		47	31/33	-32	63	
	AN287	44		47	30/32	-70	64	
	AN294	52		49	30/32	-84	64	
BGM1034N7	AN268 AN269	56	50	63	22	- ⁵⁾	65	TSSNP-7-10

Notes: 1) Rejection is defined as [Gain at 1575 MHz] – [Attenuation at stop band frequency];
2) IP_{-1dB} is measured at 900 and 1710 MHz;
3) IMD2 is measured at 1575 MHz with f_{in} = 787.5 MHz with P_{in} = +15 dBm;
4) IIP₃ is measured with f₁ = 1713 MHz and f₂ = 1850 MHz with P₁/P₂ = +10 dBm;
5) On request;
6) All Infineon GNSS FEM products offer ESD robustness higher than 6 kV at RF input pin according to IEC61000-4-2 contact discharge standard;
7) Please visit our www.infineon.com/rf-nav.frontend for alternative devices.

TVS Diodes for Antenna ESD Protection

Product	Application	V _{RWM} [V]	ESD ¹⁾ [kV]	V _{CL} ²⁾ [V _{CL}]@ [A]	R _{dyn} ³⁾ [Ω]	I _{PP} ⁴⁾ [A]	V _{CL} ⁵⁾ [V]	C _T ⁶⁾ [pF]	Protected Lines	Package
ESD108-B1-CSP0201 ESD119-B1-CSP01005	med. P _{RF} AN392	±5.5	±25	±20@±16 ±31@±30	0.76	1 2.5	8.5 11	0.25	1	WLL-2-1 WLL-2-2
ESD105-B1-02EL/02ELS	med. P _{RF}	±5.5	±25	±14@±16 ±20@±30	0.35	2 5	8.5 11	0.3	1	TSLP-2-20 TSSLP-2-4
ESD101-B1-02EL/02ELS	med. P _{RF} AN327	±5.5	±12	±18@±8 ±30@±16	1.5	-	-	0.10	1	TSLP-2-20 TSSLP-2-4
ESD103-B1-02EL/02ELS	high P _{RF} AN327	±15	±10	±36@±8 ±48@±16	1.8	-	-	0.10	1	TSLP-2-20 TSSLP-2-4

Notes: 1) Electrostatic discharge as per IEC61000-4-2, contact discharge; 2) TLP clamping voltage for 100 ns pulse length;
3) Dynamic resistance (ON-resistance) evaluated with TLP measurement (100 ns pulse length);
4) Maximum peak pulse current according to IEC61000-4-5 (8/20 μs); 5) Clamping Voltage at I_{PP,max} according to IEC61000-4-5 (8/20 μs);
6) Typical capacitance at 1 MHz (unless specified), 0 V, I/O vs. GND;
7) Please visit www.infineon.com/protection/low-cap.esd-diodes for alternative devices.

5 Wireless-LAN, Unlicensed LTE (LTE-U) and Licensed Assisted Access (LAA)

5.1 Wireless-LAN Applications

Wireless Local Area Network (WLAN) or Wi-Fi is one of the most important connectivity functions in notebooks, smartphones, and tablet PCs. Wi-Fi conforming to IEEE 802.11b/g/n at 2.4 GHz has been widely implemented over many years. Today Wi-Fi is not only used for high-data-rate access to the internet, but also in different applications such as home entertainment with wireless high-quality multimedia signal transmission such as Wireless High-Definition Multimedia Interface (HDMI) in TV sets and DVD players, etc. The crowded WLAN networks running at 2.4 GHz often have a lot of interference; as a result, Wi-Fi applications running at 5 to 6 GHz per IEEE 802.11a/ac/n are becoming more common. Wireless@Home devices such as home networking notebooks, mass data storage drives, and printers often now use 5-6 GHz Wi-Fi for high-speed wireless connections.

With the arrival of new wireless devices such as tablets, Voice over Internet Protocol (VoIP) devices, game consoles, ebooks etc., the requirements for wireless data quality have become more stringent than ever. New WLAN standards are being developed to cater to these high-throughput requirements by using

- i) Higher-order modulation schemes
- ii) Wider channel bandwidth
- iii) Multiple data streams

The 802.11ac is an extension of 802.11n, providing a minimum of 500 Mbps single link and up to 1 Gbps overall throughput, running in the 5 GHz band. The draft 802.11ad provides up to 7 Gbps throughput using approximately 2 GHz of spectrum at 60 GHz over a short range. The following table shows the evolution of IEEE 802.11 standards.



Summary of 802.11 a/b/g/n/ac/ad standards

Standard	Frequency Range [GHz]	Data Rate [Mbps]	Count of Channels	Channel Bandwidth [MHz]	Modulation Scheme	MIMO Streams
802.11	2.4 – 2.5	2	14 ¹⁾	20	DSSS, FHSS	1
802.11b	2.4 – 2.5	11	14 ¹⁾	20	DSSS	1
802.11g	2.4 – 2.5	54	14 ¹⁾	20	OFDM, DSSS	1
802.11n	2.4 – 2.5	54	up to 14 ¹⁾	20, 40	OFDM	4
802.11a	5.1 – 5.9	54	42 ²⁾	20	OFDM 64QAM	1
802.11n	5.1 – 5.9	600 (4x4 MIMO)	up to 42 ²⁾	20, 40	OFDM	4
802.11ac	5.1 – 5.9	1300 (3 streams)	up to 42 ²⁾	20, 40, 80, 160	256QAM	up to 8, MU-MIMO
802.11ad	57 - 64	up to 7000	--	50,100, 250 MHz up to 4 GHz	16QAM	--

Notes: 1) Three non-overlapping channels; 2) Twelve non-overlapping channels.

5.1.1 Key Features of WLAN Rx Front-End Devices

Key performance metrics for any WLAN application are speed of data transfer, and coverage. These factors are greatly influenced by transmitted power, receiver sensitivity, noise, and interference.

Low Noise Figure

A Wi-Fi router has to receive relatively weak signals from Wi-Fi enabled devices such as mobile phones. Therefore, it should have high sensitivity to detect a weak signal in the presence of strong interfering signals. The sensitivity of the receiver can be improved by using a low-noise amplifier as the first block of the receiver Front-End (FE) to reduce the Noise Figure (NF) of the overall system.

High Linearity

WLAN systems are subject to co-channel interference and also interference from strong co-existing cellular signals. High linearity characteristics such as Input 3rd Intercept Point (IIP3) and input compression point are required to improve an application's ability to distinguish between desired signals and spurious signals received close together.

Infineon offers a wide Radio Frequency (RF) product portfolio for Wi-Fi, including:

- Discrete transistors & Monolithic Microwave Integrated Circuit (MMIC) Low Noise Amplifiers (LNAs)
- Power detection diodes
- RF Complementary Metal-Oxide-Semiconductor (CMOS) and pin diode switches

For these kinds of high-data-rate wireless communication systems, it is essential to ensure the quality of the link path. Major performance criteria of this equipment must be met with regard to sensitivity, signal strength, and interference immunity with enough link budgets.

In addition, Infineon also offers RF Electro-Static Discharge (ESD) protection diodes. The ESD protection diode series, [ESD108-B1-CSP0201](#) and ESD103-B1-[02EL/02ELS](#), have a line capacitance value of only 0.2 pF and 0.1 pF respectively and can protect the system from ESD strikes up to 8 kV contact discharge according to the IEC-61000-4-2 standard.

5.1.2 Dual-Band (2.4–6.0 GHz) WLAN (IEEE 802.11a/b/g/n) Front-End

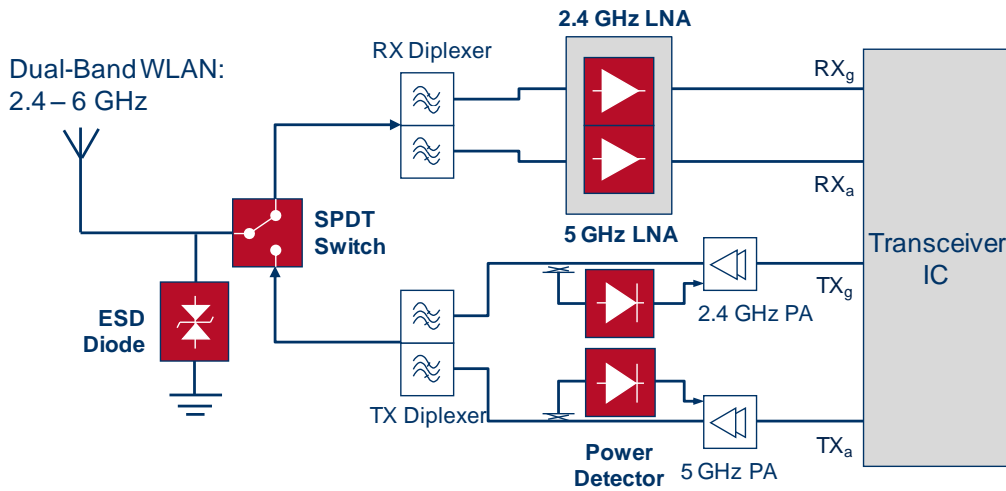

WLAN Application Example 1: Dual-band (2.4–6.0 GHz) WLAN (IEEE 802.11a/b/g/n) FE

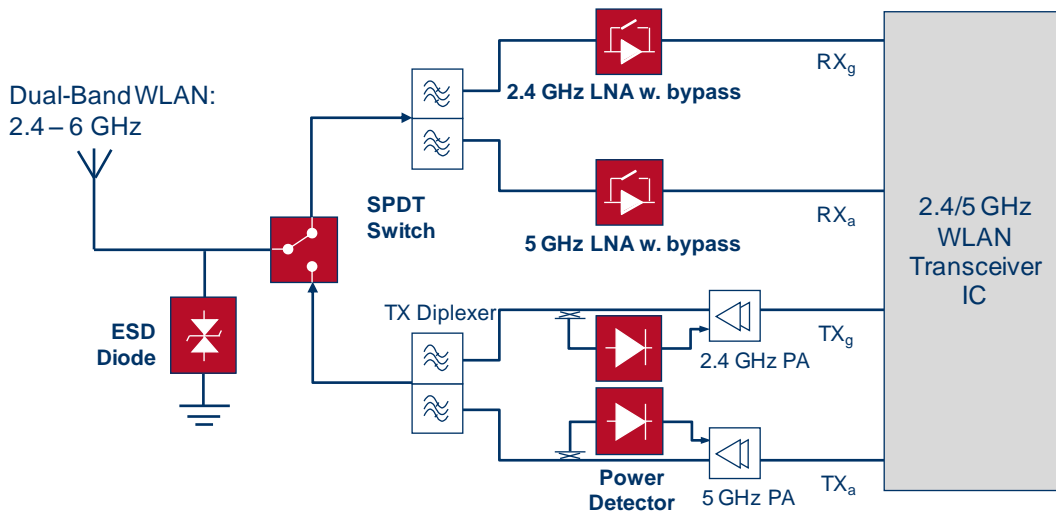

WLAN Application Example 2: Dual-band (2.4–6.0 GHz) WLAN (IEEE 802.11a/b/g/n/ac) FE

5.1.3 MIMO Configurations for WLAN (IEEE 802.11b/g/n and IEEE 802.11a/n/ac) Applications

IEEE 802.11n at 2.4 GHz and at 5 GHz bands introduced the Multiple Input Multiple Output (MIMO) topologies in advanced high-data-rate WLAN applications. MIMO exploits multipath propagation known as space-division multiplexing. The transmitter IC multiplexes a data stream into multiple spatial streams, and transmits each spatial stream through separate antennas to corresponding antennas on the receiving end.

Doubling the number of spatial streams from one to two effectively doubles the data rate. However, increased power consumption due to the presence of multiple transmitter and receiver chains presents a major challenge in optimizing the battery life of the device. Infineon’s products offer very low power consumption, thus optimizing the battery life of the device.

The following block diagram illustrates a dual-band WLAN MIMO FE. Please refer to the previous sections for the corresponding products for each function block.

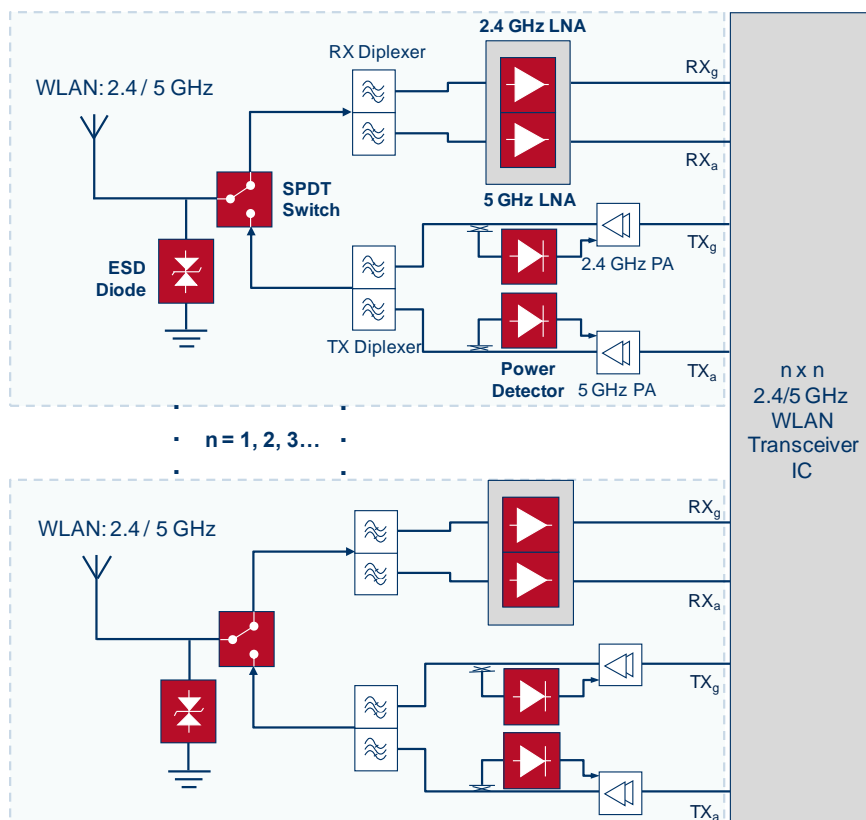

WLAN MIMO Application Example: Dual-band WLAN 2.4 & 5 GHz IEEE 802.11b/g/n and 802.11a/n/ac N_xN MIMO FE with dual-band antennas, dual-band TX and RX paths using dual-band LNAs

5.1.4 WLAN (IEEE 802.11a/b/g/n) Front-End Devices

RF MMIC LNAs

Product	Application Note	Gain [dB]	NF [dB]	IP _{-1dB} [dBm]	IIP ₃ [dBm]	Supply [V]	Current [mA]	Package
2.4 GHz LNA								
BGA6H1BN6 ¹⁾	1800-2700	14.3/-2.8	0.8/2.8	-6/+12	+3/+25	1.5...3.3	5.5/0.09	TSNP-6-2
BGA7H1N6	AN365	13.0	0.7	2	5	1.5...3.6	4.9	TSNP-6-2
BGA777N7	AN370	16.4/-7.0	1.2/7.0	-9/-1	-3/+5	2.8	4.4/0.5	TSNP-7-1
BGB741L7ESD	AN207 TR102	17.5 18.7	1.5 1.1	-4.0 -6.7	-1.2 +2	3.0	10.0 10.8	TSLP-7-1
BGA622L7	AN089	12.6	1.3	-15	-4	2.8	5.4	SOT343
5 GHz LNA								
BGB741L7ESD	AN207	12	2.0	-1	8.5	3.0	6	TSLP-7-1
BGB707L7ESD	TR1012 ¹⁾	13.3	2.3	-6	-4.3	2.8	3.2	TSLP-7-1

Notes: 1) On request; 2) Please visit www.infineon.com/rf-mmic for alternative devices.

RF CMOS Switches

Product	Type	App. Note	Supply [V]	V _{ctrl} ¹⁾ [V]	IL ²⁾ [dB]	Isolation [dB]	P _{0.1dB} ³⁾ [dBm]	P _{n,max} ⁴⁾ [dBm]	Ctrl. Int. ⁵⁾	Package
2.4 GHz Switches										
BGS12AL7-4 BGS12AL7-6	SPDT	AN175	2.4...3.6	1.4...3.6	0.5	25	> 21	21	GPIO	TSLP-7-4 TSLP-7-6
BGS13SN9	SP3T	on request	1.8...3.3	1.35...V _{dd}	0.33 / 0.35	30 / 27	>30	30	GPIO	TSNP-9-2
2.4 GHz and 5 GHz Broadband Switches										
BGS12SN6	SPDT	AN332	1.8...3.3	1.4...3.3	0.3/0.5 ⁶⁾	32/30 ⁶⁾	>30	30	GPIO	TSNP-6-2

Notes: 1) Digital Control Voltage; 2) IL = Insertion Loss; 3) 0.1 dB compression point; 4) Maximum input power; 5) Control Interface; 6) Value at 2.4 GHz/5 GHz; 7) Please visit www.infineon.com/rfswitches for alternative devices.

RF Schottky Diodes for Power Detectors

Product ¹⁾	Application Note	C _T ²⁾ [pF]	@V _R [V]	V _F [mV]	@I _F [mA]	V _F [mV]	@I _F [mA]	I _R [μA]	@V _R [V]	Package
BAT62-02V	AN185	0.35	0	580	2	-	-	< 10	40	SC79
BAT15-02EL BAT15-02ELS	on request	0.26	0	230	1	320	10	< 5	4	TSLP-2-19 TSSLP-2-3

Notes: 1) D = Dual; T = Triple; Q = Quadruple; 2) at 1 MHz; 3) Please visit www.infineon.com/rf-mixer-detector-schottky-diodes for alternative devices.

RF Transistor LNAs

Product	Application Note	Gain [dB]	NF [dB]	IP _{1dB} [dBm]	IIP ₃ [dBm]	Supply [V]	Current [mA]	Package
2.4 GHz LNA								
BFP842ESD	AN322	19.3	0.8	-9.9	2.6	3.0	11.9	SOT343
BFR840L3RHESD	AN339	20.8	1.38	-18.6	-7.2	3.0	9.0	TSLP-3-9
BFR740L3RH	AN173	18.0	0.7	-10	+1	3.0	14.7	TSLP-3-9
5 GHz LNA								
BFR840L3RHESD	AN281 AN290	15.1	1.0	-8	+2	3.0	9.4	TSLP-3-9
BFR740L3RH	AN170	14.3	1.3	-5	+4	3.0	12.9	TSLP-3-9
2.4 GHz & 5 GHz Broadband LNA								
BFR843EL3	AN307	18.5/13.3	1.0/1.3	-12.1/-7.5	-1.9/2.8	3.0	12.2	TSLP-3-9
BFR840L3RHESD	AN292	18.5/15	1.1/1.4	-15/-12.6	-5.5/0.3	3.0	9.4	TSLP-3-9

Note: Please visit www.infineon.com/lna up to 12 GHz for alternative devices.

TVS Diodes for Antenna ESD Protection

Product	Application	V _{RWM} [V]	ESD ¹⁾ [kV]	V _{CL} ²⁾ [V _{CL}]@[A]	R _{dyn} ³⁾ [Ω]	I _{PP} ⁴⁾ [A]	V _{CL} ⁵⁾ [V]	C _T ⁶⁾ [pF]	Protected Lines	Package
ESD108-B1-CSP0201 ESD119-B1-CSP01005	med. P _{RF} AN392	±5.5	±25	±20@±16 ±31@±30	0.76	1 2.5	8.5 11	0.25	1	WLL-2-1 WLL-2-2
ESD105-B1-02EL/02ELS	med. P _{RF}	±5.5	±25	±14@±16 ±20@±30	0.35	2 5	8.5 11	0.3	1	TSLP-2-20 TSSLP-2-4
ESD101-B1-02EL/02ELS	med. P _{RF} AN327	±5.5	±12	±18@±8 ±30@±16	1.5	-	-	0.10	1	TSLP-2-20 TSSLP-2-4
ESD103-B1-02EL/02ELS	high P _{RF} AN327	±15	±10	±36@±8 ±48@±16	1.8	-	-	0.10	1	TSLP-2-20 TSSLP-2-4

Notes: 1) Electrostatic discharge as per IEC61000-4-2, contact discharge; 2) TLP clamping voltage for 100 ns pulse length;
 3) Dynamic resistance (ON-resistance) evaluated with TLP measurement (100 ns pulse length);
 4) Maximum peak pulse current according to IEC61000-4-5 (8/20 μs); 5) Clamping Voltage at I_{PP,max} according to IEC61000-4-5 (8/20 μs);
 6) Typical capacitance at 1 MHz (unless specified), 0 V, I/O vs. GND;
 7) Please visit www.infineon.com/protection/low-cap.esd-diodes for alternative devices.

5.2 Unlicensed LTE (LTE-U) and Licensed Assisted Access (LAA)

5.2.1 LTE-U and LAA as data rate booster for LTE-A

Unlicensed Long-Term Evolution (LTE-U) and Licensed Assisted Access (LAA) are new concepts to increase the available RF bandwidth of mobile users to achieve much higher data rates than are possible with common LTE bands. For the Frequency-Division Duplexing (FDD) mode with the traditional LTE bands up to 2.7 GHz, intra- and inter-band carrier aggregation is used with up to 5 channels and a maximum 100 MHz bandwidth. However, this technology requires quite complex RF FE architecture, and suffers from performance degradation. On the other hand, LTE-U and LAA can make use of the 5- to 6-GHz ISM (Industrial, Science and Medicine) bands and can easily use much a higher bandwidth (up to 160 MHz) with a simple RF FE. This additional available bandwidth can be combined with the common LTE bands at lower frequencies. The first figure below shows how these solutions work together with the LTE FDD operation by using carrier aggregation or link aggregation. The second picture shows one of the first proposals by mobile phone makers in 3GPP for a 5-GHz LAA downlink to support common FDD up-/downlinks.

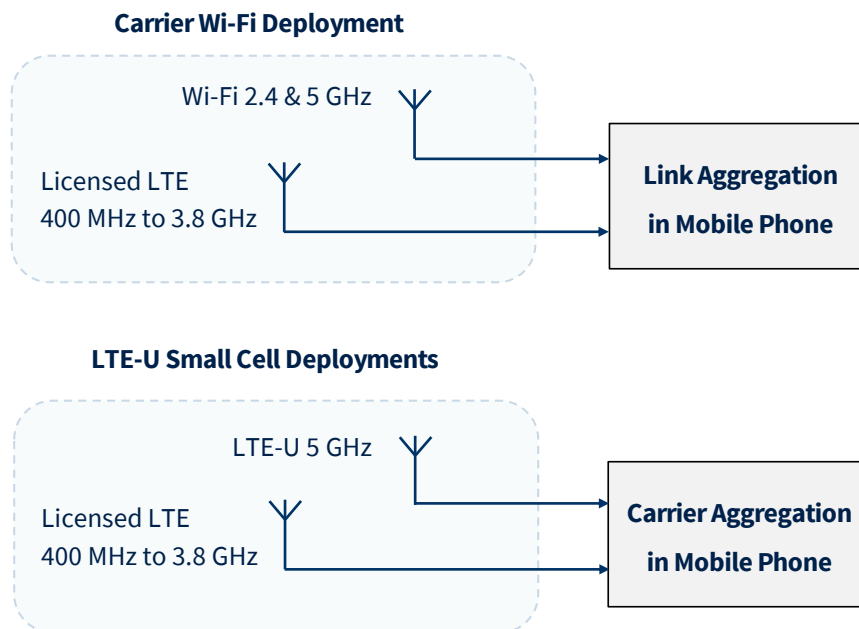

LTE FDD operation supported by LAA and LTE-U techniques using link or carrier aggregation

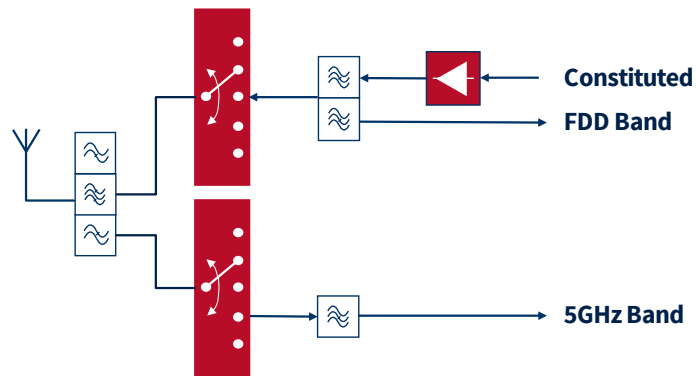

Block diagram of a 5-GHz LAA to support common FDD operation using carrier aggregation

Nevertheless, this technology must co-exist with the WLAN IEEE802.a/ac standard. Various implementations in the system are under investigation by 3rd Generation Partnership Project (3GPP) members to monitor and control the usage of the channels in 5 to 6 GHz to avoid link collision between WLAN and LTE-U or LAA. One method to avoid link collision is for a system to listen to a channel for at least 3 ms to make sure that it is free for use before the radio link is established and packages can be sent out.

5.2.2 LTE-U and LAA Front-End Devices

RF MMIC LNAs

Product	Application Note	Gain [dB]	NF [dB]	IP _{-1dB} [dBm]	IIP ₃ [dBm]	Supply [V]	Current [mA]	Package
BGB741L7ESD	AN207	12	2.0	-1	8.5	3.0	6	TSLP-7-1
BGB707L7ESD	TR1012 ¹⁾	13.3	2.3	-6	-4.3	2.8	3.2	TSLP-7-1

Notes: 1) On request; 2) Please visit www.infineon.com/rf-mmhc for alternative devices.

RF CMOS Switches

Product	Type	App. Note	Supply [V]	V _{ctrl} ¹⁾ [V]	IL ²⁾ [dB]	Isolation [dB]	P _{0.1dB} ³⁾ [dBm]	P _{in,max} ⁴⁾ [dBm]	Ctrl. Int. ⁵⁾	Package
BGS12SN6	SPDT	AN332	1.8...3.3	1.4...3.3	0.3/0.5 ⁶⁾	32/30 ⁶⁾	>30	30	GPIO	TSPN-6-2

Notes: 1) Digital Control Voltage; 2) IL = Insertion Loss; 3) 0.1 dB compression point; 4) Maximum input power; 5) Control Interface; 6) Value at 2.4 GHz/5 GHz; 7) Please visit www.infineon.com/rfswitches for alternative devices.

RF Schottky Diodes for Power Detectors

Product ¹⁾	Application Note	C _T ²⁾ [pF]	@V _k [V]	V _f [mV]	@I _f [mA]	V _f [mV]	@I _f [mA]	I _r [μA]	@V _k [V]	Package
BAT62-02V	AN185	0.35	0	580	2	-	-	< 10	40	SC79
BAT15-02EL BAT15-02ELS	on request	0.26	0	230	1	320	10	< 5	4	TSLP-2-19 TSSLP-2-3

Notes: 1) D = Dual; T = Triple; Q = Quadruple; 2) at 1 MHz; 3) Please visit www.infineon.com/rf-mixer-detector-schottky-diodes for alternative devices.

RF Transistor LNAs

Product	Application Note	Gain [dB]	NF [dB]	IP _{-1dB} [dBm]	IIP ₃ [dBm]	Supply [V]	Current [mA]	Package
BFR840L3RHESD	AN281 AN290	15.1	1.0	-8	+2	3.0	9.4	TSLP-3-9
BFR740L3RH	AN170	14.3	1.3	-5	+4	3.0	12.9	TSLP-3-9

Notes: Please visit www.infineon.com/lna up to 12 GHz for alternative devices.

TVS Diodes for Antenna ESD Protection

Product	Application	V _{RWM} [V]	ESD ¹⁾ [kV]	V _{CL} ²⁾ [V _{CL}]@ [A]	R _{dyn} ³⁾ [Ω]	I _{PP} ⁴⁾ [A]	V _{CL} ⁵⁾ [V]	C _T ⁶⁾ [pF]	Protected Lines	Package
ESD108-B1-CSP0201 ESD119-B1-CSP01005	med. P _{RF} AN392	±5.5	±25	±20@±16 ±31@±30	0.76	1 2.5	8.5 11	0.25	1	WLL-2-1 WLL-2-2
ESD105-B1-02EL/02ELS	med. P _{RF}	±5.5	±25	±14@±16 ±20@±30	0.35	2 5	8.5 11	0.3	1	TSLP-2-20 TSSLP-2-4
ESD101-B1-02EL/02ELS	med. P _{RF} AN327	±5.5	±12	±18@±8 ±30@±16	1.5	-	-	0.10	1	TSLP-2-20 TSSLP-2-4
ESD103-B1-02EL/02ELS	high P _{RF} AN327	±15	±10	±36@±8 ±48@±16	1.8	-	-	0.10	1	TSLP-2-20 TSSLP-2-4

Notes: 1) Electrostatic discharge as per IEC61000-4-2, contact discharge; 2) TLP clamping voltage for 100 ns pulse length; 3) Dynamic resistance (ON-resistance) evaluated with TLP measurement (100 ns pulse length); 4) Maximum peak pulse current according to IEC61000-4-5 (8/20 μs); 5) Clamping Voltage at I_{PP,max} according to IEC61000-4-5 (8/20 μs); 6) Typical capacitance at 1 MHz (unless specified), 0 V, I/O vs. GND; 7) Please visit www.infineon.com/protection/low-cap.esd-diodes for alternative devices.

6 FM Radio and Mobile TV

Frequency Modulation (FM) radio has a long history, starting from its development in 1933. Today, FM radio is an integral part of almost all mobile phones. The headset cable can serve as an antenna for FM reception. Its size (~75 cm) is ideal to have good reception. Nevertheless, no FM reception is possible when the headset is not available.

There is a clear market trend to be able to use FM radio without the headset cable, meaning that the antenna has to be integrated inside the phone. However, there are space constraints on the antenna design. Shrinking the size of the antenna introduces a high loss in the system which reduces the receiver's sensitivity. The major FM topologies widely used in the market are:

- **FM Receiver (RX) only** (Application 1): Only the FM radio receive function is implemented
- **FM Transmitter (TX) and RX** (Application 2): The FM path is used for both FM radio reception and FM signal transmission, streaming music from the mobile phone to other FM receivers such as car radio and home hi-fi systems

Infineon's low noise amplifiers (LNAs) for mobile FM applications include Monolithic Microwave Integrated Circuits (MMICs) BGB707L7ESD, BGB717L7ESD, and BGB719N7ESD, as well as low-cost transistors such as BFR340F. They solve the problem of the short FM antenna in mobile phones through better impedance match between the FM antenna and the FM receiver. Therefore, they can keep the system signal-to-noise ratio as good as with a headset.

BGB707L7ESD offers the flexibility to match various antenna and receiver input impedances. The highly integrated BGB719N7ESD is the compact solution that offers the best performance for high-ohmic antenna and 50-Ohm receiver input impedance. The integrated active biasing enables consistent stable operation with varying temperature and process variations. It is used in all kinds of mobile devices such as mobile phones, personal digital assistant (PDAs), portable FM radio, MP3 players etc.

Putting Infineon's Electro-Static Discharge (ESD) protection diode from the [ESD108-B1-CSP0201](#) and [ESD103-B1-02EL/02ELS](#) series in front of the LNA increases the system's ESD robustness up to 8 kV contact discharge (IEC61000-4-2) at the RF input. The diode has a parasitic capacitance of only 0.2 pF.

Infineon's Single-Pole Double-Throw SPDT switch BGS12 series can be used to switch between the headset and the embedded antenna in Application 1 or between transmit and receive FM functions in Application 2.

Please visit www.infineon.com/fmradio for more details on the latest product and application information for FM radio.

6.1 FM Radio with Embedded Antenna

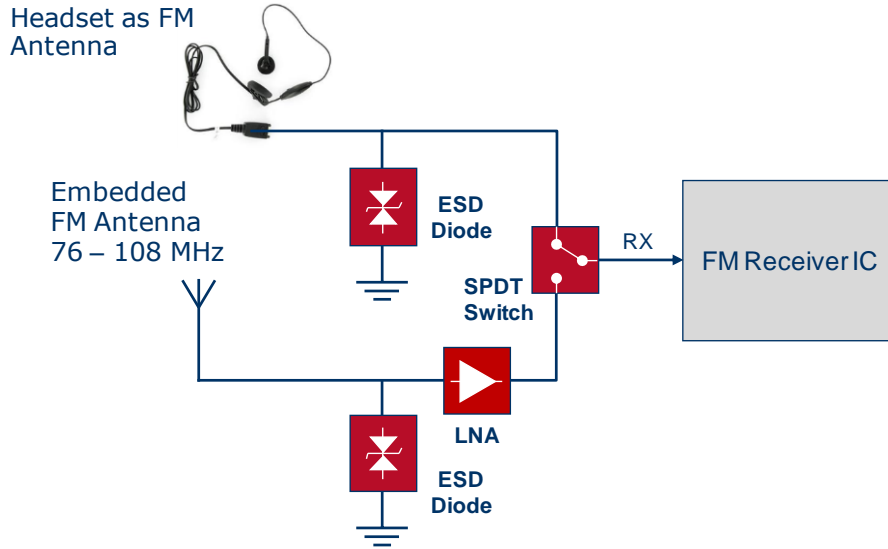

Application 1: FM reception only

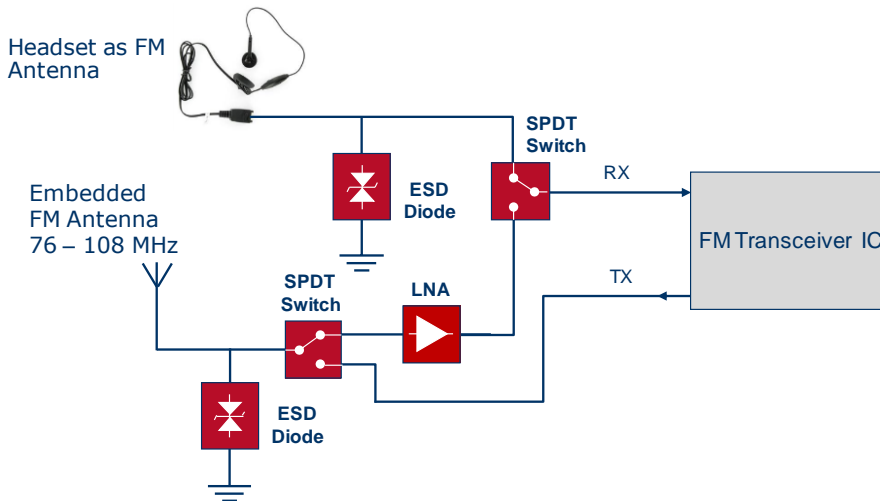

Application 2: FM transmit/receive function block

RF MMIC LNAs

Product	Application Note	Gain ⁴⁾ [dB]	NF ⁴⁾ [dB]	IP _{1dB} ⁴⁾ [dBm]	IIP ₃ ⁴⁾ [dBm]	Supply [V]	Current ⁴⁾ [mA]	Package
BGA729N6 ³⁾	on request	16.3/-4	1.1/4.3	-15/+5	-6/+17	1.5...3.3	6.0/0.5	TSNP-6-2
BGB719N7ESD	AN255 ¹⁾ TR1062 ²⁾	13.5 14.5	1.2 1.7	-6 -11	-14 -16	3.0 3.0	2.8 2.8	TSNP-7-6
BGB707L7ESD	AN177 ¹⁾ AN181 ²⁾	12.0 15.0	1.0 1.3	-5 -10	-12 -6	3.0 2.8	3.0 4.2	TSLP-7-1
BGB717L7ESD	AN176 ¹⁾	12.0	1.0	-5	-12	3.0	3.0	TSLP-7-1
BGB741L7ESD	TR130 ²⁾	16.1	1.2	-8.9	0.3	3.0	6.0	TSLP-7-1

Notes: 1) For high-ohmic antenna; 2) For 50-Ω antenna;
 3) LNA with two gain modes (high-gain/low-gain); 4) Values in high-gain (HG) / low-gain (LG) mode;
 5) Please visit www.infineon.com/itelna for alternative devices.

RF Transistor LNAs

Product	Application Note	Gain [dB]	NF [dB]	IP _{1dB} [dBm]	IIP ₃ [dBm]	Supply [V]	Current [mA]	Package
BFR340F	AN200 ¹⁾ AN205 ²⁾	15.5 15.6	1.4 1.9	-27 -25	-16 -16	1.8 1.8	2.9 3.0	TSFP-4
BFP460	AN203 ²⁾ AN204 ²⁾	14.9 17.1	1.1 1.2	-26 -24	-17 -16	1.8 2.6	3.0 4.2	SOT343
BFP540ESD	AN202 ²⁾	13.5	1.0	-26	-16	1.8	3.0	SOT343

Notes: 1) For high-ohmic antenna; 2) For 50-Ω antenna;
 3) Please visit www.infineon.com/rf-transistors for alternative devices.

RF CMOS Switches

Product	Type	App. Note	Supply [V]	V _{ctrl} ¹⁾ [V]	IL ²⁾ [dB]	Isolation [dB]	P _{o,1dB} ³⁾ [dBm]	P _{n,max} ⁴⁾ [dBm]	Ctrl. Int. ⁵⁾	Package
BGS12AL7-4 BGS12AL7-6	SPDT	AN175	2.4...3.6	1.4...3.6	0.3	50	> 21	21	GPIO	TSLP-7-4 TSLP-7-6
BGS12SN6	SPDT	AN332	1.8...3.3	1.4...3.3	0.2	40	>30	30	GPIO	TSNP-6-2
BGS13SN9	SP3T	on request	1.8...3.3	1.35...V _{dd}	0.33 / 0.35	30 / 27	>30	30	GPIO	TSNP-9-2

Notes: 1) Digital Control Voltage; 2) IL = Insertion Loss;
 3) 0.1 dB compression point; 4) Maximum input power;
 5) Control Interface; 6) Please visit www.infineon.com/rfswitches for alternative devices.

TVS Diodes for Antenna ESD Protection

Product	Application	V _{RWM} [V]	ESD ¹⁾ [kV]	V _{CL} ²⁾ [V _{CL}]@ [A]	R _{dyn} ³⁾ [Ω]	I _{PP} ⁴⁾ [A]	V _{CL} ⁵⁾ [V]	C _T ⁶⁾ [pF]	Protected Lines	Package
ESD108-B1-CSP0201 ESD119-B1-CSP01005	med. P _{RF} AN392	±5.5	±25	±20@±16 ±31@±30	0.76	1 2.5	8.5 11	0.25	1	WLL-2-1 WLL-2-2
ESD105-B1-02EL/02ELS	med. P _{RF}	±5.5	±25	±14@±16 ±20@±30	0.35	2 5	8.5 11	0.3	1	TSLP-2-20 TSSLP-2-4
ESD101-B1-02EL/02ELS	med. P _{RF} AN327	±5.5	±12	±18@±8 ±30@±16	1.5	-	-	0.10	1	TSLP-2-20 TSSLP-2-4
ESD103-B1-02EL/02ELS	high P _{RF} AN327	±15	±10	±36@±8 ±48@±16	1.8	-	-	0.10	1	TSLP-2-20 TSSLP-2-4

Notes: 1) Electrostatic discharge as per IEC61000-4-2, contact discharge; 2) TLP clamping voltage for 100 ns pulse length;
 3) Dynamic resistance (ON-resistance) evaluated with TLP measurement (100 ns pulse length);
 4) Maximum peak pulse current according to IEC61000-4-5 (8/20 μs); 5) Clamping Voltage at I_{PP,max} according to IEC61000-4-5 (8/20 μs);
 6) Typical capacitance at 1 MHz (unless specified), 0 V, I/O vs. GND;
 7) Please visit www.infineon.com/protection/low-cap.esd-diodes for alternative devices.

6.2 TV Reception in Mobile Phones

Mobile phones today are all-in-one devices. They have not only wireless functions for voice and data but also entertainment features. Mobile TV is one of the most fascinating features. It brings live news and entertainment programs onto the phone display and enables people not to miss their favorite programs.

Infineon’s mobile TV LNAs BGB741L7 are especially designed for the mobile TV reception with 50- or 75-Ohm interfaces, while our RF transistors offer cost-effective solutions to improve the signal-to-noise ratio and therefore the quality of the TV reception. Those LNAs together with Infineon’s ESD protection diode from the [ESD108-B1-CSP0201](#) and ESD103-B1-[02EL/02ELS](#) series improve systems' ESD performance up to 8 kV contact discharge (IEC61000-4-2) at the antenna input. The parasitic capacitance is only 0.2 pF.

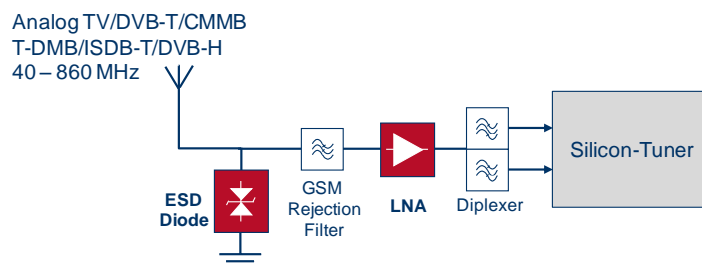

RF MMIC LNAs

Product	Application Note	Gain ²⁾ [dB]	NF ²⁾ [dB]	IP _{-1dB} ²⁾ [dBm]	IIP ₃ ²⁾ [dBm]	Supply [V]	Current ²⁾ [mA]	Package
BGA729N6 ¹⁾	on request	16.3/-4	1.1/4.3	-15/+5	-6/+17	1.5...3.3	6.0/0.5	TSNP-6-2
BGB707L7ESD	AN232	13.0	1.5	-7	-11	3.0	2.9	TSLP-7-1
BGB741L7ESD	AN206	15.0	1.5	-8	-3	2.8	5.4	TSLP-7-1

Notes: 1) LNA with two gain modes (high-gain/low-gain); 2) Values in high-gain (HG) / low-gain (LG) mode; 3) Please visit www.infineon.com/rf-mmhc for alternative devices.

RF Transistor LNAs

Product	Application Note	Gain [dB]	NF [dB]	IP _{-1dB} [dBm]	IIP ₃ [dBm]	Supply [V]	Current [mA]	Package
BFP640ESD	AN218	16.5	0.83	-11.6	+9.3	3.0	7.3	SOT343
BFP540ESD	AN142	14.2	1.5	-21	-13	5.0	3.3	SOT343
BFR380L3	AN221	10.5	2.2	-2	+7	3.3	16.8	TSLP-3-1

Note: Please visit www.infineon.com/rf-transistors for alternative devices.

TVS Diodes for Antenna ESD Protection

Product	Application	V_{RWM} [V]	ESD ¹⁾ [kV]	V_{CL} ²⁾ [V _{CL}]@[A]	R_{dyn} ³⁾ [Ω]	I_{PP} ⁴⁾ [A]	V_{CL} ⁵⁾ [V]	C_T ⁶⁾ [pF]	Protected Lines	Package
ESD108-B1-CSP0201 ESD119-B1-CSP01005	med. P _{RF} AN392	±5.5	±25	±20@±16 ±31@±30	0.76	1 2.5	8.5 11	0.25	1	WLL-2-1 WLL-2-2
ESD105-B1-02EL/02ELS	med. P _{RF}	±5.5	±25	±14@±16 ±20@±30	0.35	2 5	8.5 11	0.3	1	TSLP-2-20 TSSLP-2-4
ESD101-B1-02EL/02ELS	med. P _{RF} AN327	±5.5	±12	±18@±8 ±30@±16	1.5	-	-	0.10	1	TSLP-2-20 TSSLP-2-4
ESD103-B1-02EL/02ELS	high P _{RF} AN327	±15	±10	±36@±8 ±48@±16	1.8	-	-	0.10	1	TSLP-2-20 TSSLP-2-4

- Notes:
- 1) Electrostatic discharge as per IEC61000-4-2, contact discharge;
 - 2) TLP clamping voltage for 100 ns pulse length;
 - 3) Dynamic resistance (ON-resistance) evaluated with TLP measurement (100 ns pulse length);
 - 4) Maximum peak pulse current according to IEC61000-4-5 (8/20 μs);
 - 5) Clamping Voltage at $I_{PP,max}$ according to IEC61000-4-5 (8/20 μs);
 - 6) Typical capacitance at 1 MHz (unless specified), 0 V, I/O vs. GND;
 - 7) Please visit www.infineon.com/protection/low-cap.esd-diodes for alternative devices.

6.3 TV Reception with Band Selection Switch

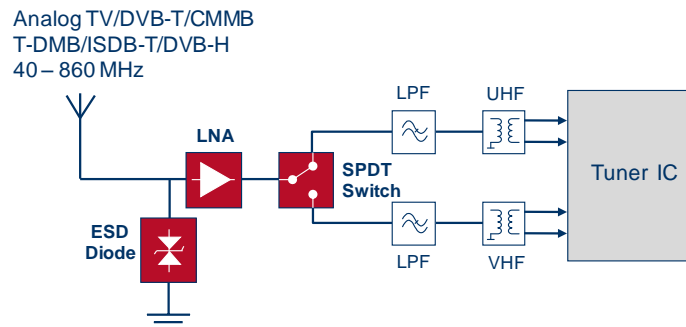

RF MMIC LNAs

Product	Application Note	Gain [dB]	NF [dB]	IP _{-1dB} [dBm]	IIP ₃ [dBm]	Supply [V]	Current [mA]	Package
BGB707L7ESD	AN232	13.0	1.5	-7	-11	3.0	2.9	TSLP-7-1
BGB741L7ESD	AN206	15.0	1.5	-8	-3	2.8	5.4	TSLP-7-1

Notes: Please visit www.infineon.com/rf-mmic for alternative devices.

RF Transistor LNAs

Product	Application Note	Gain [dB]	NF [dB]	IP _{-1dB} [dBm]	IIP ₃ [dBm]	Supply [V]	Current [mA]	Package
BFP640ESD	AN218	16.5	0.83	-11.6	+9.3	3.0	7.3	SOT343
BFP540ESD	AN142	14.2	1.5	-21	-13	5.0	3.3	SOT343
BFR380L3	AN221	10.5	2.2	-2	+7	3.3	16.8	TSLP-3-1

Notes: Please visit www.infineon.com/rf-transistors for alternative devices.

RF CMOS Switches

Product	Type	App. Note	Supply [V]	V _{ctrl} ¹⁾ [V]	IL ²⁾ [dB]	Isolation [dB]	P _{-0.1dB} ³⁾ [dBm]	P _{in,max} ⁴⁾ [dBm]	Ctrl. Int. ⁵⁾	Package
BGS12AL7-4 BGS12AL7-6	SPDT	AN175	2.4...3.6	1.4...2.8	0.35	> 32	> 21	21	GPIO	TSLP-7-4 TSLP-7-6
BGS12SN6	SPDT	AN332	1.8...3.3	1.35...3.3	0.25	> 40	>30	30	GPIO	TSPN-6-2

Notes: 1) Digital Control Voltage; 2) IL = Insertion Loss; 3) 0.1 dB compression point; 4) Maximum input power; 5) Control interface; 6) Please visit www.infineon.com/rfswitches for alternative devices.

TVS Diodes for Antenna ESD Protection

Product	Application	V _{RWM} [V]	ESD ¹⁾ [kV]	V _{CL} ²⁾ [V _{CL}]@[A]	R _{dyn} ³⁾ [Ω]	I _{PP} ⁴⁾ [A]	V _{CL} ⁵⁾ [V]	C _T ⁶⁾ [pF]	Protected Lines	Package
ESD108-B1-CSP0201 ESD119-B1-CSP01005	med. P _{RF} AN392	±5.5	±25	±20@±16 ±31@±30	0.76	1 2.5	8.5 11	0.25	1	WLL-2-1 WLL-2-2
ESD105-B1-02EL/02ELS	med. P _{RF}	±5.5	±25	±14@±16 ±20@±30	0.35	2 5	8.5 11	0.3	1	TSLP-2-20 TSSLP-2-4

Notes: 1) Electrostatic discharge as per IEC61000-4-2, contact discharge; 2) TLP clamping voltage for 100 ns pulse length; 3) Dynamic resistance (ON-resistance) evaluated with TLP measurement (100 ns pulse length); 4) Maximum peak pulse current according to IEC61000-4-5 (8/20 μs); 5) Clamping Voltage at I_{pp,max} according to IEC61000-4-5 (8/20 μs); 6) Typical capacitance at 1 MHz (unless specified), 0 V, I/O vs. GND; 7) Please visit www.infineon.com/protection/low-cap.esd-diodes for alternative devices.

6.4 FM and TV Reception in Mobile Phones with Band Selection Switch

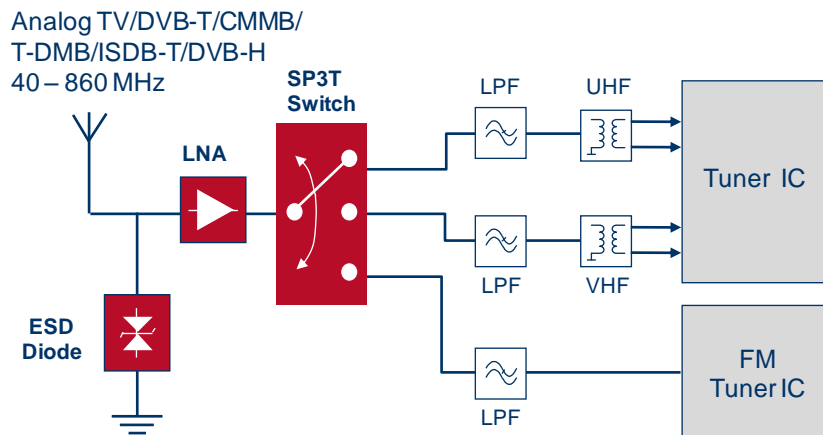

RF MMIC LNAs

Product	Application Note	Gain [dB]	NF [dB]	IP _{-1dB} [dBm]	IIP ₃ [dBm]	Supply [V]	Current [mA]	Package
BGB707L7ESD	AN232	13.0	1.5	-7	-11	3.0	2.9	TSLP-7-1
BGB741L7ESD	AN206	15.0	1.5	-8	-3	2.8	5.4	TSLP-7-1

Notes: Please visit www.infineon.com/rf-mmic for alternative devices.

RF Transistor LNAs

Product	Application Note	Gain [dB]	NF [dB]	IP _{-1dB} [dBm]	IIP ₃ [dBm]	Supply [V]	Current [mA]	Package
BFP640ESD	AN218	16.5	0.83	-11.6	+9.3	3.0	7.3	SOT343
BFP540ESD	AN142	14.2	1.5	-21	-13	5.0	3.3	SOT343
BFR380L3	AN221	10.5	2.2	-2	+7	3.3	16.8	TSLP-3-1

Notes: Please visit www.infineon.com/rf-transistors for alternative devices.

RF CMOS Switches

Product	Type	App. Note	Supply [V]	V _{ctrl} ¹⁾ [V]	IL ²⁾ [dB]	Isolation [dB]	P _{-0.1dB} ³⁾ [dBm]	P _{in,max} ⁴⁾ [dBm]	Ctrl. Int. ⁵⁾	Package
BGS13SN9	SP3T	on request	1.8...3.3	1.35...V _{dd}	0.33 / 0.35	30 / 27	>30	30	GPIO	TSNP-9-2

Notes: 1) Digital Control Voltage; 2) IL = Insertion Loss; 3) 0.1 dB compression point; 4) Maximum input power; 5) Control Interface; 6) Please visit www.infineon.com/rfswitches for alternative devices.

TVS Diodes for Antenna ESD Protection

Product	Application	V _{RWM} [V]	ESD ¹⁾ [kV]	V _{CL} ²⁾ [V _{CL}]@ [A]	R _{dyn} ³⁾ [Ω]	I _{PP} ⁴⁾ [A]	V _{CL} ⁵⁾ [V]	C _T ⁶⁾ [pF]	Protected Lines	Package
ESD108-B1-CSP0201 ESD119-B1-CSP01005	med. P _{RF} AN392	±5.5	±25	±20@±16 ±31@±30	0.76	1 2.5	8.5 11	0.25	1	WLL-2-1 WLL-2-2
ESD105-B1-02EL/02ELS	med. P _{RF}	±5.5	±25	±14@±16 ±20@±30	0.35	2 5	8.5 11	0.3	1	TSLP-2-20 TSSLP-2-4

Notes: 1) Electrostatic discharge as per IEC61000-4-2, contact discharge; 2) TLP clamping voltage for 100 ns pulse length; 3) Dynamic resistance (ON-resistance) evaluated with TLP measurement (100 ns pulse length); 4) Maximum peak pulse current according to IEC61000-4-5 (8/20 μs); 5) Clamping Voltage at I_{PP,max} according to IEC61000-4-5 (8/20 μs); 6) Typical capacitance at 1 MHz (unless specified), 0 V, I/O vs. GND; 7) Please visit www.infineon.com/protection/low-cap.esd-diodes for alternative devices.

7 ESD and ESD/EMI Interface Protection

In today's electronics, being faster, smaller and smarter creates profitability by enabling new and better applications. The race to pack more and more high-speed functions in a smaller space accelerates miniaturization roadmaps. However, the downscale of semiconductor chips together with the increase of doping levels results in a dramatic reduction of the thin gate oxide layer and the width of the pn-junction in semiconductor chips. This, in combination with greater circuit population, increases the susceptibility of the semiconductor chips to Electro-Static Discharge (ESD).

Subsequent failures of electronic equipment can be noticed as hard failures, latent damage, or temporary malfunctions. Hard failures are easier to spot, and in general require the failed device to be replaced. In the best case, the failure will be detected before the equipment leaves the factory and customers will never receive it. Failures leading to temporary malfunctions of equipment or latent failures are quite common and very difficult to detect or trace in the field. Temporary malfunctions may go unreported but can result in negative customer impressions as the user may need to reset the equipment. A product recall for swapping or repairing parts due to ESD failures may cause the company a cost several times higher than the cost of the device itself.

The only way to ensure stable operation and maximum reliability at the system level is to ensure that equipment is properly protected by an external protection device against electrostatic discharge and transients.

Infineon's Value Proposition

Improve ESD immunity at the system level by providing first-class protection beyond the IEC61000-4-2 level-4 standard, and offering:

- Superior multi-strike absorption capability
- Safe and stable clamping voltages to protect even the most sensitive electronic equipment
- Protection devices that fully comply with high-speed signal quality requirements
- Array solutions that save space on the board and reduce part count
- Easy-to-use single devices for space-constrained applications
- Discrete components that drain extremely low leakage currents and help to extend battery duration
- Packages enabling easy Printed Circuit Board (PCB) layout

For detailed information about our Transient Voltage Suppression (TVS) diode portfolio and their applications, please refer to our [Application Guide – Part 3: Protection](#). You can also visit our website for protection devices: www.infineon.com/protection.

7.1 Interface Protection with TVS Protection Diodes

Infineon offers various high-performance types of discrete TVS protection devices to protect our customers' mobile phones from ESD attacks. Below is a short overview of the available TVS protection devices from Infineon for various RF and digital interfaces of mobile phones. For detailed information about our TVS diode portfolio and applications, please refer to our [Application Guide – Part 3: Protection](#). You can also visit our website for protection devices: www.infineon.com/protection.

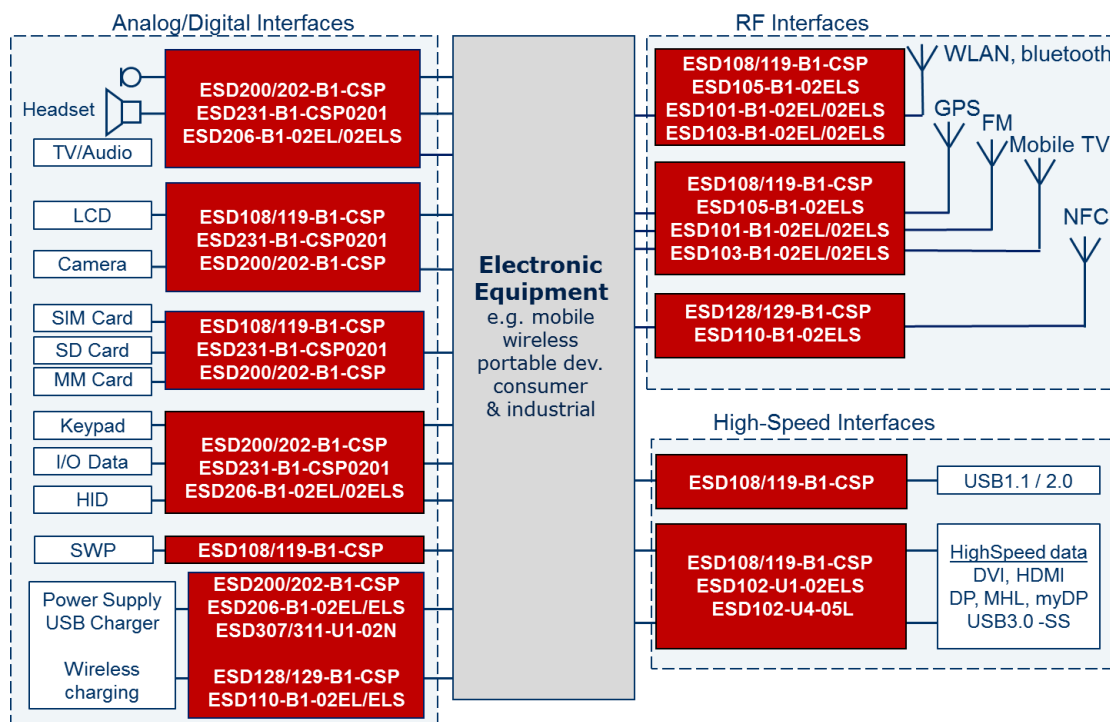

Interface protection with discrete ESD TVS diodes

In a modern mobile phone there are a lot of open access points that could permit ESD strikes to reach the inner PCB, such as the charging port, audio ports (line out, headset jack), and data interfaces (USB).

Other very risky paths for ESD strikes are the case bottom, and air gaps in the enclosure or the microphone/speaker. Often the point of entrance for the ESD strike is not obvious.

To provide proper ESD protection for the inner PCB, it is mandatory to place fast-responding TVS protection diodes at specific locations. Depending on the position to be protected (e.g. where the signal frequency is low and therefore device capacitance does not matter), general-purpose TVS diodes can be used. They are listed in the table below, "TVS ESD Diodes for general-purpose interfaces."

Dedicated low-capacitance TVS diodes must be used for high-speed data lines to avoid any impact on signal integrity. As higher the data rate will be as more the device capacitance matters. For the 5 Gb/s USB3.0 data rate the ESD protection device capacitance should be below 0.5pF. Please refer to the table below, “TVS ESD Diodes for high-speed digital interface” regarding these low-capacitance TVS diodes.

TVS ESD Diodes for General-Purpose Interfaces

Product	Application	V_{RWM} [V]	ESD ¹⁾ [kV]	V_{CL} ²⁾ [V _{CL}]@[A]	R_{dyn} ³⁾ [Ω]	I_{PP} ⁴⁾ [A]	V_{CL} ⁵⁾ [V]	C_T ⁶⁾ [pF]	Protected Lines	Package
ESD200-B1-CSP0201 ESD202-B1-01005	General purpose	±5.5	±16	+13/-13@±16	0.2	3	12.5	6.5	1	WLL-2-1 WLL-2-2
ESD231-B1-CSP0201	General purpose	±5.5	±30	±12@±16 ±16@±30	0.3	2 9	8 10	3.4	1	WLL-2-1
ESD204-B1 02EL/02ELS	General purpose	+14/-8	±18	+28/-27@±16 +35/-35@±30	0.5/0.6	1 -1	17 -23	4	1	TSLP-2-19 TSSLP-2-3
ESD207-B1 02EL/02ELS	General purpose	±3.3	±30	±7@±16 ±9@±30	0.13	1 8	4.5 6.8	14	1	TSLP-2-19 TSSLP-2-3
ESD206-B1 02EL/02ELS ESD206-B1-02V	General purpose	±5.5	±30	±9@±16 ±12@±30	0.13 0.16	1 6	7.5 9.6	12	1	TSLP-2-19 TSSLP-2-3 SC79
ESD5V0S5US	General purpose	+5.0	±30	±10@±16 ±14@±30	0.25	10	10.5	70	5	SOT363

Notes: 1) Electrostatic discharge as per IEC61000-4-2, contact discharge; 2) TLP clamping voltage for 100 ns pulse length;
3) Dynamic resistance (ON-resistance) evaluated with TLP measurement (100 ns pulse length);
4) Maximum peak pulse current according to IEC61000-4-5 (8/20 μs); 5) Clamping Voltage at $I_{PP,max}$ according to IEC61000-4-5 (8/20 μs);
6) Typical capacitance at 1 MHz (unless specified), 0 V, I/O vs. GND;
7) Please visit www.infineon.com/protection/low-cap.esd-diodes for alternative devices.

TVS ESD Diodes for High Speed Interfaces

Product	Application	V_{RWM} [V]	ESD ¹⁾ [kV]	V_{CL} ²⁾ [V _{CL}]@[A]	R_{dyn} ³⁾ [Ω]	I_{PP} ⁴⁾ [A]	V_{CL} ⁵⁾ [V]	C_T ⁶⁾ [pF]	Protected Lines	Package
ESD108-B1-CSP0201 ESD119-B1-CSP01005	MIPI, HDMI, USB2.0-HS	±5.5	±25	±20@±16 ±31@±30	0.76	1 2.5	8.5 11	0.25	1	WLL-2-1 WLL-2-2
ESD102-U4-05L	USB3.0-SS MIPI, HDMI	+3.3	±20	8@16 11@30	0.2	1 3	4.8 6.2	0.35	4	TSLP-5-2
ESD102-U1-02ELS	USB3.0-SS MIPI, HDMI	+3.3	±20	8@16 11@30	0.2	1 3	4.8 6.2	0.35	1	TSSLP-2-3
ESD105-B1- 02EL/02ELS	USB3.0-SS	±5.5	±25	±14@±16 ±20@±30	0.35	2 5	8.5 11	0.3	1	TSLP-2-20 TSSLP-2-4
ESD200-B1-CSP0201 ESD202-B1-01005	General purpose	±5.5	±16	+13/-13@±16	0.2	3	12.5	6.5	1	WLL-2-1 WLL-2-2
ESD5V5U5ULC	USB2.0-HS, V _{CC}	+5.5	±25	8.9@16 11.5@30	0.2	6	10	0.45	4	SC74

Notes: 1) Electrostatic discharge as per IEC61000-4-2, contact discharge;
2) TLP clamping voltage for 100 ns pulse length;
3) Dynamic resistance (ON-resistance) evaluated with TLP measurement (100 ns pulse length);
4) Maximum peak pulse current according to IEC61000-4-5 (8/20 μs);
5) Clamping Voltage at $I_{PP,max}$ according to IEC61000-4-5 (8/20 μs);
6) Typical capacitance at 1 MHz (unless specified), 0 V, I/O vs. GND;
7) Please visit our webpage www.infineon.com/protection/low-cap.esd-diodes for alternative devices.

7.2 Interface Protection with Integrated ESD/EMI Devices

Due to the increasing number of wireless functions integrated into mobile phones, it's essential to provide both immunity against ESD and robustness against Electromagnetic Interference (EMI).

For applications where a high number of input/outputs (I/Os) must be protected from ESD and EMI, a smart integration of the required protection features will reduce necessary space on the PCB and make the layout easier.

Secure Digital Card (SD) and Micro Secure Digital Memory (μ SD) card provide six high-speed lines and one Vcc line. In a lot of applications, these lines are exposed to ESD events during mobile phone use, and especially during insertion or removal of the SD / μ SD card.

State-of-the art SD / μ SD cards work in UHS-I Mode, with a 208-MHz clock rate. To avoid any impact on signal integrity (SI) or rise/fall time, the device capacitance must be minimized. The required EMI protection is provided by the EMI resistor in conjunction with the load capacitance present in the SD / μ SD link.

Infineon's BGF148 is based on a "PI" structure with a 20-Ohm EMI resistor. Line capacitance is about 1 pF. In combination with the load capacitance of 10 pF (meeting the μ SD-card specification), the EMI filter response is guaranteed.

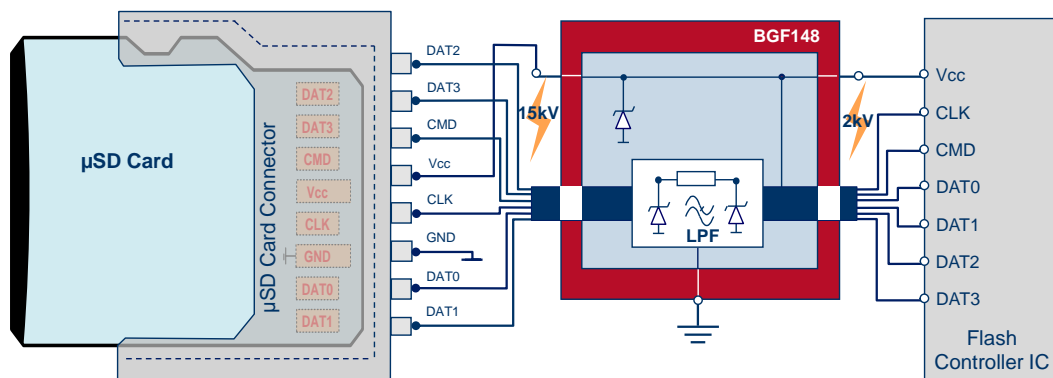

Integrated ESD/EMI devices dedicated for HS and UHS I SIM Card

Integrated ESD/EMI Protection Device

Product	Application	V_{RWM} [V]	ESD ¹⁾ [kV]	V_{CL} ²⁾ [V _{CL}]@[A]	R_{ESD} ³⁾ [Ω]	I_{PP} ⁴⁾ [A]	V_{CL} ⁵⁾ [V]	C_T ⁶⁾ [pF]	Protected Lines	Package
BGF148	(μ)SD Card Interface	± 5.5	± 15	8.5@1 9@16	20	-	-	1.2	7	TSNP-14-2

Notes: 1) Electrostatic discharge as per IEC61000-4-2, contact discharge; 2) TLP clamping voltage @ output, for input 100 ns pulse length;
3) ESD resistor between input and output TVS diode;
4) Maximum peak pulse current according to IEC61000-4-5 (8/20 μ s); 5) Clamping Voltage at $I_{PP,max}$ according to IEC61000-4-5 (8/20 μ s);
6) Typical line capacitance at 1 MHz (unless specified), 0 V, I/O vs. GND;
7) Please visit our webpage www.infineon.com/protection/low-cap.esd-diodes for alternative devices.

7.3 Near-Field Communication

Near-Field Communication (NFC) is a short-range high-frequency wireless communication technology that enables the exchange of data between devices over about a 10-20 cm distance. The technology is a simple extension of the ISO/IEC 14443 proximity-card standard (proximity card, radio-frequency identification (RFID) that combines the interface of a smartcard and a reader into a single device. An NFC device can communicate with both existing ISO/IEC 14443 smartcards and readers, as well as with other NFC devices, and is thereby compatible with existing contactless infrastructure already in use for public transportation and payment. It operates within the globally available and unlicensed 13.56 MHz radio frequency ISM band (Industrial, Scientific and Medical). Plenty of applications are present in the market already, and more will enter the market soon.

- **Mobile Commerce:**

- Mobile ticketing - for airplanes, for public transport, for concerts/events
- Mobile payment - the device acts as a debit/ credit payment card
- Electronic money - such as a stored value card

- **Proof of Identity:**

- Access control for buildings, or IT equipment
- Electronic keys - car keys, house/office keys and hotel room keys, etc.

NFC can be used to configure and initiate other wireless network connections such as Bluetooth and Wi-Fi. The time-consuming configuration procedure for identification to a Bluetooth or Wi-Fi system is reduced by a “one touch” step for two mobiles equipped with NFC devices. To provide the required security level for all these applications, the NFC modem is combined with a secure controller (NFC module). In a mobile phone, the NFC module is also linked to the Subscriber Identity Module (SIM) card.

In a mobile phone the NFC Front-End (FE) is often separated into the Transmitter (TX) driver with the Electromagnetic compatibility (EMC) filter and Receiver (RX) signal decoupling, and the high impedance 13.56-MHz resonator. The 13.56 MHz resonator includes the loop antenna (resonator’s inductance) and a parallel capacitor (resonator’s capacitance).

Because of the loop antenna size, the 13.56 MHz resonance circuit is often installed in the bottom shell of the mobile phone, which can be removed by the user. An interface is generated inside the NFC FE which then becomes ESD-critical. Proper ESD protection is mandatory to protect the EMI filter and the NFC FE driver, which is located on the main mobile phone PCB.

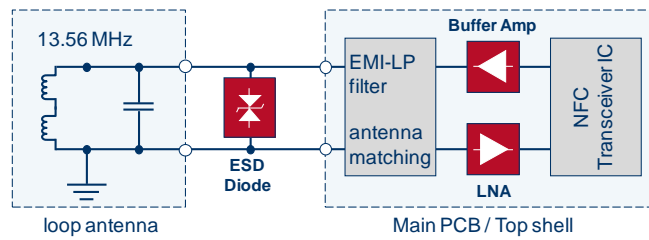

NFC with single-line LNA and RF driver

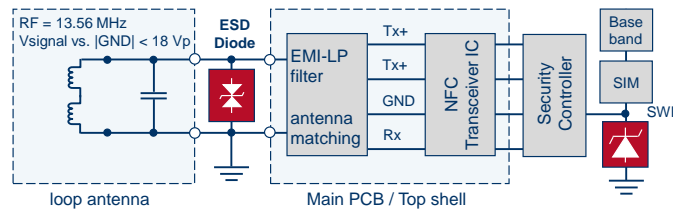

ESD protection for a single-ended NFC antenna system

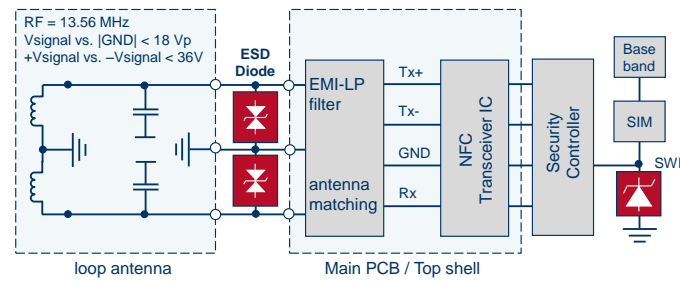

ESD protection for a differential NFC antenna system

RF MMIC Buffer Amplifier

Product	Application Note	Gain [dB]	NF [dB]	OP _{1dB} [dBm]	OIP ₃ [dBm]	Supply [V]	Current [mA]	Package
BGA616	TR1065 ¹⁾	17.5	2.9	16.5	28	3.3	62	SOT343

Notes: 1) On request; 2) Please visit <http://www.infineon.com/rfrtransistors> for alternative devices.

RF MMIC LNA

Product	Application Note	Gain [dB]	NF [dB]	IP _{1dB} [dBm]	IIP ₃ [dBm]	Supply [V]	Current [mA]	Package
BGA420	TR1065 ¹⁾	17.7	1.9	-19.5	-3	3.3	8.1	SOT343

Notes: 1) On request; 2) Please visit <http://www.infineon.com/rfmmics> for alternative devices.

TVS Diodes for Antenna ESD Protection

Product	App. Note	V _{RWM} [V]	ESD ¹⁾ [kV]	V _{CL} ²⁾ [V _{CL}]@ [A]	R _{dyn} ³⁾ [Ω]	I _{PP} ⁴⁾ [A]	V _{CL} ⁵⁾ [V]	C _T ⁶⁾ [pF]	Protected Lines	Package
ESD128-B1-CSP0201 ESD129-B1-CSP01005 ESD110-B1-02EL/02ELS	NFC-RF AN244	±18	±15	±32@16 ±28@16 ±34@25	0,85 0.65	1 1	17 17-	0,3 0.3	1 1	WLL-2-1 WLL-2-2 TSLP-2-20 TSSLP-2-4
ESD108-B1-CSP0201 ESD119-B1-CSP01005	SWP AN392	±5.5	±25	±20@±16 ±31@±30	0.76	1 2.5	8.5 11	0.25	1	WLL-2-1 WLL-2-2

Notes: 1) Electrostatic discharge as per IEC61000-4-2, contact discharge; 2) TLP clamping voltage for 100 ns pulse length; 3) Dynamic resistance (ON-resistance) evaluated with TLP measurement (100 ns pulse length); 4) Maximum peak pulse current according to IEC61000-4-5 (8/20 μs); 5) Clamping Voltage at I_{PP,max} according to IEC61000-4-5 (8/20 μs); 6) Typical capacitance at 1 MHz (unless specified), 0 V, I/O vs. GND; 7) Please visit www.infineon.com/protection/low-cap.esd-diodes for alternative devices.

7.4 Reverse Polarity Protection (RPP) for USB Charger

In most battery-operated portable equipment, it is possible to install the battery in the reverse direction, leading to accidental short circuits and other fatal errors to the equipment. Today’s battery terminals are usually marked with colors and the terminal posts themselves are mechanically different. Nevertheless, the possibility for reversed battery installation is still present, at least for a short-duration connection. For these systems, a designer must ensure that any flow of reverse current is low enough to avoid damaging the circuit or the battery. A variety of circuits can be used to achieve this. The easiest way to safeguard gear against reverse battery protection would be a series diode in the positive supply line of the Electronic Control Unit (ECU), depending on the load.

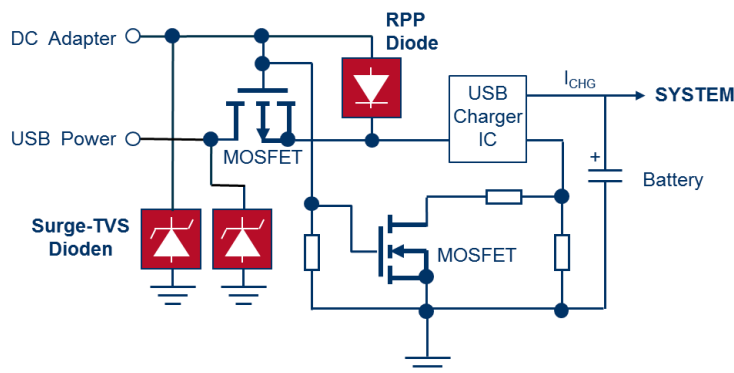

Surge TVS Diodes

Product	Application	V_{RWM} [V]	ESD ¹⁾ [kV]	V_{CL} ²⁾ [V _{CL}]@[A]	R_{dyn} ³⁾ [Ω]	I_{PP} ⁴⁾ [A]	V_{CL} ⁵⁾ [V]	C_T ⁶⁾ [pF]	Protected Lines	Package
ESD307-U1-02N	AN372	10	±30	17@±16 18@±30	0.05	1 34	16 24	270	1	TSNP-2-2
ESD311-U1-02N	AN372	15	±30	22@±16 23@±30	0.07	1 28	21 29	210	1	TSNP-2-2

Notes: 1) Electrostatic discharge as per IEC61000-4-2, contact discharge; 2) TLP clamping voltage for 100 ns pulse length; 3) Dynamic resistance (ON-resistance) evaluated with TLP measurement (100 ns pulse length); 4) Maximum peak pulse current according to IEC61000-4-5 (8/20 μs); 5) Clamping Voltage at $I_{PP,max}$ according to IEC61000-4-5 (8/20 μs); 6) Typical capacitance at 1 MHz (unless specified), 0 V, I/O vs. GND; 7) Please visit www.infineon.com/protection/low-cap.esd-diodes for alternative devices.

AF Schottky Diodes for RPP

Product ¹⁾	Application Note	C_T ²⁾ [pF]	@ V_R [V]	V_F [mV]	@ I_F [mA]	V_F [mV]	@ I_F [mA]	I_R [μA]	@ V_R [V]	Package
BAS3005A-02EL	on request	10	5	260	10	450	500	15	5	TSLP-2-17

Notes: 1) D = Dual; T = Triple; Q = Quadruple; 2) at 1 MHz; 3) Please visit www.infineon.com/rf-mixer-detector-schottky-diodes for alternative devices.

Abbreviations

Abbr.	Terms
ATSLP	Advanced Thin Small Leadless Package
ASM	Antenna Switch Module
BAW	Bulk Acoustic Wave
CA	Carrier Aggregation
CDMA	Code Division Multiple Access
COMS	Complementary Metal-Oxide-Semiconductor
CSP	Chip Scale Package
DC	Direct Current
DCS	Digital Cellular Service
DL	Downlink
DPDT	Double Pole Double Throw
DP	Display Port
DSSS	Direct Sequence Spread Spectrum
DVI	Digital Visual Interface
ECU	Electronic Control Unit
EDGE	Enhanced Data Rates for GSM Evolution
EM	Electro-Magnetic
EMI	Electromagnetic Interference
ESD	Electro-Static Discharge
E-UTRA	Evolved Universal Terrestrial Radio Access
FDD	Frequency-Division Duplexing
FEM	Front-End Module
FHSS	Frequency-Hopping Spread Spectrum
FM	Frequency Modulation
GLONASS	Global Orbiting Navigation Satellite System
GNSS	Global Navigation Satellite System
GPIO	General Purpose Input/Output
GPS	Global Positioning System
GSM	Global System for Mobile Communication
HBM	Human Body Model
HDMI	High-Definition Multimedia Interface
HSPA	High-Speed Packet Access
HSPA+	Evolved High-Speed Packet Access
IC	integrated circuit
IL	Insertion Loss
IMD	Intermodulation Distortion
IPD	Integrated Passive Device
IMT	International Mobile Telecommunications
ISM	Industrial, Scientific and Medical
LNA	Low Noise Amplifier
LMM	LNA multiplexer modules
LTE	Long-Term Evolution
LTE-A	LTE-Advanced
MHL	Mobile High-Definition Link
MIPI	Mobile Industry Processor Interface
MMIC	Monolithic Microwave Integrated Circuit
MIMO	Multiple Input Multiple Output
MU	Multi-User

Abbr.	Terms
NF	Noise Figure
NFC	Near-Field Communication
OFDM	Orthogonal Frequency Division Multiplexing
PCS	Personal Communications Services
PCB	Printed Circuit Board
PDA	Personal Digital Assistant
PIFA	Planar Inverted F antenna
PIN-Diode	Positive-Intrinsic-Negative diode
PND	Personal Navigation Devices
QAM	Quadrature Amplitude Modulation
RF	Radio Frequency
RFFE	RF Front-End Control Interface
RFID	radio-frequency identification
RFS	RF and Sensors
RoHS	Restriction of Hazardous Substances
RPP	Reverse Polarity Protection
RX	Receiver
SAR	Search and Rescue
SAW	Surface Acoustic Wave
SD	Secure Digital Card
SI	Signal Integrity
SIM	Subscriber Identity Module
SPI	Serial Peripheral Interface
SPxT	Single Pole x Throw (Switch)
SV-LTE	Simultaneous Voice and LTE
TDD	Time-division duplexing
TD-SCDMA	Time Division-Synchronous Code Division Multiple Access
TD-LTE	Time Division Long-Term Evolution
T(S)SLP	Thin (Super) Small Leadless Package
TRP	Total Radiated Power
TSNP	Thin Small Non Leaded Package
TTF	Time to First fix
TT	Truth Table
TVS	Transient Voltage Suppression
TX	Transmitter
UE	User Equipment
UHS-I	Ultra High Speed SD card in Version 3.01
UMTS	Universal Mobile Telecommunications System
UL	Uplink
USB	Universal Serial Bus
VoIP	Voice over IP
W-CDMA	Wideband-Code Division Multiple Access
WLAN	Wireless Local Area Network
μSD	Micro Secure Digital Memory
3GPP	3rd Generation Partnership Project

Alphanumerical List of Symbols

Symbol	Term	Unit
C_T	Total Diode capacitance	[pF]
ESD	Voltage of ESD pulse	[kV]
I_F	Forward current	[mA]
I_R	Reverse current	[μ A]
I_{PP}	Maximum peak pulse current	[A]
IIP_3	Input 3 rd intercept point	[dBm]
IL	Insertion loss	[dB]
IMD2	2 nd order intermodulation distortion	[dBm]
IP_{-1dB}	Input 1dB compression point	[dBm]
LDO	Low drop out	[V]
NF	Noise figure	[dB]
OIP_3	Output 3 rd intercept point	[dBm]
OP_{-1dB}	Output 1dB compression point	[dBm]
$P_{-0.1dB}$	0.1dB compression point	[dBm]
$P_{in,max}$	Maximum input power	[dBm]
R_{dyn}	Dynamic resistance	[Ω]
r_F	Differential forward resistance	[Ω]
V_{CL}	Clamping voltage	[V]
V_{ctrl}	Digital control voltage	[V]
V_{dd}	DC supply voltage	[V]
V_F	Forward voltage	[mV]
V_R	Reverse voltage	[V]
V_{RWM}	Reverse working voltage	[V]
T_L	Storage time	[ns]

Package Information

Package (JEITA-code)	
X	L × W × H
	PIN-Count
	Scale 1:1
All Dimensions in mm	



All products are available in green (RoHS compliant)

ATSLP-12-1 (-) 13 1.9 × 1.1 × 0.65 3:1	ATSLP-12-4 (-) 13 1.9 × 1.1 × 0.65 3:1	ATSLP-14 (-) 15 1.9 × 1.5 × 0.65 4:1	SC79 (-) 2 1.6 × 0.8 × 0.55 5:1	SOT23 (-) 3 2.9 × 2.4 × 1.1 2:1
SOT323 (SC-70) 3 2.0 × 2.1 × 0.9 3:1	SOT343 (SC-82) 4 2.0 × 2.1 × 0.9 3:1	FWLP-6-1 (-) 6 0.778 × 0.528 × 0.34 6:1	TSFP-4 (-) 4 1.4 × 1.2 × 0.55 5:1	TSLP-2-1 (-) 2 1.0 × 0.6 × 0.4 5:1
TSLP-2-7 (-) 2 1.0 × 0.6 × 0.39 5:1	TSLP-2-17 (-) 2 1.0 × 0.6 × 0.39 5:1	TSLP-2-19 (-) 2 1.0 × 0.6 × 0.31 5:1	TSLP-2-20 (-) 2 1.0 × 0.6 × 0.31 5:1	TSLP-3-1 (-) 3 1.0 × 0.6 × 0.4 5:1
TSLP-3-9 (-) 3 1.0 × 0.6 × 0.31 5:1	TSLP-4-4 (-) 4 1.2 × 0.8 × 0.4 4:1	TSLP-4-7 (-) 4 1.2 × 0.8 × 0.39 4:1	TSLP-5-2 (-) 5 1.3 × 0.8 × 0.39 4:1	TSLP-6-2 (-) 6 1.1 × 0.7 × 0.39 4:1
TSLP-6-3 (-) 6 1.1 × 0.9 × 0.39 4:1	TSLP-6-4 (-) 6 1.1 × 0.7 × 0.31 4:1	TSLP-7-1 (-) 7 2.0 × 1.3 × 0.4 3:1	TSLP-7-4 (-) 7 2.3 × 1.5 × 0.4 3:1	TSLP-7-6 (-) 7 1.4 × 1.26 × 0.39 3:1
TSLP-9-3 (-) 9 1.15 × 1.15 × 0.31 5:1	TSLP-10-1 (-) 10 1.55 × 1.15 × 0.31 4:1	TSNP-6-2 (-) 6 1.1 × 0.7 × 0.375 4:1	TSNP-7-1 (-) 7 2.0 × 1.3 × 0.375 3:1	TSNP-7-6 (-) 7 1.4 × 1.26 × 0.375 3:1

Application Guide for Mobile Communication

Package Information



TSNP-7-10 (-)		TSNP-8-1 (-)		TSNP-9-1 (-)		TSNP-10-1 (-)		TSNP-14-2 (-)	
7	2.3 × 1.7 × 0.73	8	1.1 × 1.1 × 0.375	8	1.1 × 1.1 × 0.375	10	1.5 × 1.1 × 0.375	15	1.95 × 1.8 × 0.375
3:1		3:1		3:1		3:1		2:1	
TSNP-14-3 (-)		TSNP-16-1 (-)		TSNP-16-6 (-)		TSNP-20-1 (-)		TSNP-26-2 (-)	
15	1.95 × 1.8 × 0.375	16	2.3 × 2.3 × 0.38	17	2.3 × 2.3 × 0.73	21	2.3 × 2.3 × 0.73	27	3.4 × 2.6 × 0.73
2:1		2:1		2:1		2:1		2:1	
TSNP-26-3 (-)		TSSLP-2-1 (-)		TSSLP-2-2 (-)		TSSLP-2-3 (-)		TSSLP-2-4 (-)	
17	3.2 × 2.8 × 0.77	2	0.62 × 0.32 × 0.31	2	0.62 × 0.32 × 0.31	2	0.62 × 0.32 × 0.31	2	0.62 × 0.32 × 0.31
2:1		7:1		7:1		5:1		5:1	
WLL-2-1 (-)		WLL-2-2 (-)							
2	0.58 × 0.28 × 0.15	2	0.43 × 0.23 × 0.15						
10:1		12:1							

Support Material

Data Sheets / Application Notes / Technical Reports	http://www.infineon.com/rfandprotectiondevices
Products <ul style="list-style-type: none"> - RF CMOS Switches & Antenna Tuning Solutions - LTE MMIC LNAs - RF MMICs - RF Transistors - RF Diodes - PIN Diodes - Schottky Diodes - Varactor Diodes - ESD/EMI Protection Devices 	www.infineon.com/rfswitches www.infineon.com/ltelna www.infineon.com/rfmmics www.infineon.com/rftransistors www.infineon.com/rfdiodes www.infineon.com/pindiodes www.infineon.com/schottkydiodes www.infineon.com/varactordiodes www.infineon.com/ESDdiodes
Brochures: <ul style="list-style-type: none"> - Product Selection Guide - Application Guide for Mobile Communication - Application Guide for Industrial Applications - Application Guide for Protection - GPS Front-End Components for Mobile and Wireless Applications 	www.infineon.com/RFS_Selectionguide www.infineon.com/appguide_rf_mobile www.infineon.com/appguide_rf_industrial www.infineon.com/appguide_esd_protection www.infineon.com/gps
Sample Kits	www.infineon.com/rpdkits
Evaluation Boards, Simulation Models and Libraries Footprint Drawings Application Examples	Please check the product web pages for details or for more information please contact your sales counterpart at Infineon.

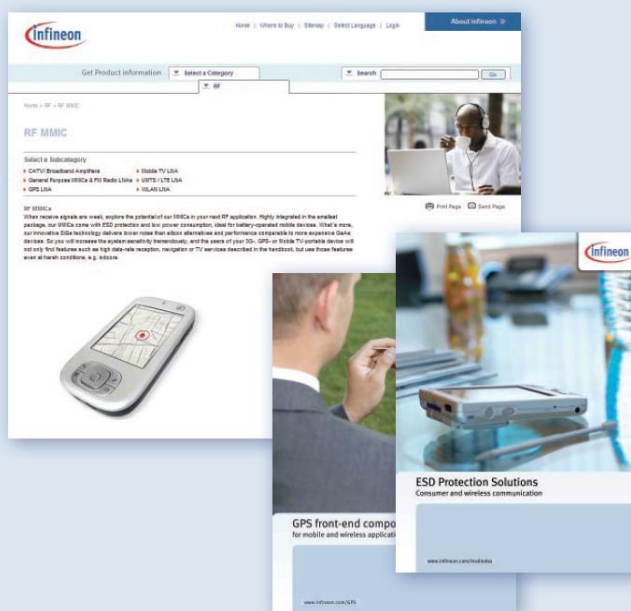

Trademarks of Infineon Technologies AG

AURIX™, C166™, CanPAK™, CIPOS™, CIPURSE™, CoolGaN™, CoolMOS™, CoolSET™, CoolSiC™, CORECONTROL™, CROSSAVE™, DAVE™, DI-POL™, DrBLADE™, EasyPIM™, EconoBRIDGE™, EconoDUAL™, EconoPACK™, EconoPIM™, EiceDRIVER™, eupec™, FCOST™, HITFET™, HybridPACK™, ISOFACE™, IsoPACK™, i-Wafer™, MIPAQ™, ModSTACK™, my-d™, NovalithIC™, OmniTune™, OPTIGA™, OptiMOS™, ORIGA™, POWERCODE™, PRIMARION™, PrimePACK™, PrimeSTACK™, PROFET™, PRO-SIL™, RASIC™, REAL3™, ReverSave™, SatRIC™, SIEGET™, SIPMOS™, SmartLEWIS™, SOLID FLASH™, SPOC™, TEMPFET™, thinQ!™, TRENCHSTOP™, TriCore™.

Other Trademarks

Advance Design System™ (ADS) of Agilent Technologies, AMBA™, ARM™, MULTI-ICE™, KEIL™, PRIMECELL™, REALVIEW™, THUMB™, μVision™ of ARM Limited, UK. ANSI™ of American National Standards Institute. AUTOSAR™ of AUTOSAR development partnership. Bluetooth™ of Bluetooth SIG Inc. CAT-ig™ of DECT Forum. COLOSSUS™, FirstGPS™ of Trimble Navigation Ltd. EMV™ of EMVCo, LLC (Visa Holdings Inc.). EPCOS™ of Epcos AG. FLEXGO™ of Microsoft Corporation. HYPERTERMINAL™ of Hilgraeve Incorporated. MCS™ of Intel Corp. IEC™ of Commission Electrotechnique Internationale. IrDA™ of Infrared Data Association Corporation. ISO™ of INTERNATIONAL ORGANIZATION FOR STANDARDIZATION. MATLAB™ of MathWorks, Inc. MAXIM™ of Maxim Integrated Products, Inc. MICROTEC™, NUCLEUS™ of Mentor Graphics Corporation. MIPI™ of MIPI Alliance, Inc. MIPS™ of MIPS Technologies, Inc., USA. muRata™ of MURATA MANUFACTURING CO., MICROWAVE OFFICE™ (MWO) of Applied Wave Research Inc., OmniVision™ of OmniVision Technologies, Inc. Openwave™ of Openwave Systems Inc. RED HAT™ of Red Hat, Inc. RFMD™ of RF Micro Devices, Inc. SIRIUS™ of Sirius Satellite Radio Inc. SOLARIS™ of Sun Microsystems, Inc. SPANSION™ of Spansion LLC Ltd. Symbian™ of Symbian Software Limited. TAIYO YUDEN™ of Taiyo Yuden Co. TEAKLITE™ of CEVA, Inc. TEKTRONIX™ of Tektronix Inc. TOKO™ of TOKO KABUSHIKI KAISHA TA. UNIX™ of X/Open Company Limited. VERILOG™, PALLADIUM™ of Cadence Design Systems, Inc. VLYNQ™ of Texas Instruments Incorporated. VXWORKS™, WIND RIVER™ of WIND RIVER SYSTEMS, INC. ZETEX™ of Diodes Zetex Limited.

Last Trademarks Update 2014-07-17

www.infineon.com

Edition <2015-05-15>

Published by

Infineon Technologies AG

81726 Munich, Germany

© 2015 Infineon Technologies AG.

All Rights Reserved.

Do you have a question about any aspect of this document?

Email: erratum@infineon.com

Document reference

AN_2015_06_PL32_002

Legal Disclaimer

THE INFORMATION GIVEN IN THIS APPLICATION NOTE (INCLUDING BUT NOT LIMITED TO CONTENTS OF REFERENCED WEBSITES) IS GIVEN AS A HINT FOR THE IMPLEMENTATION OF THE INFINEON TECHNOLOGIES COMPONENT ONLY AND SHALL NOT BE REGARDED AS ANY DESCRIPTION OR WARRANTY OF A CERTAIN FUNCTIONALITY, CONDITION OR QUALITY OF THE INFINEON TECHNOLOGIES COMPONENT. THE RECIPIENT OF THIS APPLICATION NOTE MUST VERIFY ANY FUNCTION DESCRIBED HEREIN IN THE REAL APPLICATION. INFINEON TECHNOLOGIES HEREBY DISCLAIMS ANY AND ALL WARRANTIES AND LIABILITIES OF ANY KIND (INCLUDING WITHOUT LIMITATION WARRANTIES OF NON-INFRINGEMENT OF INTELLECTUAL PROPERTY RIGHTS OF ANY THIRD PARTY) WITH RESPECT TO ANY AND ALL INFORMATION GIVEN IN THIS APPLICATION NOTE.

Information

For further information on technology, delivery terms and conditions and prices, please contact the nearest Infineon Technologies Office (www.infineon.com).

Warnings

Due to technical requirements, components may contain dangerous substances. For information on the types in question, please contact the nearest Infineon Technologies Office. Infineon Technologies components may be used in life-support devices or systems only with the express written approval of Infineon Technologies, if a failure of such components can reasonably be expected to cause the failure of that life-support device or system or to affect the safety or effectiveness of that device or system. Life support devices or systems are intended to be implanted in the human body or to support and/or maintain and sustain and/or protect human life. If they fail, it is reasonable to assume that the health of the user or other persons may be endangered.