

A NUMERICALLY OPTIMIZED CONTIGUOUS DIPLEXER

Richard L. Mole
Hughes Aircraft Company
Space and Communications Group
El Segundo, California 90245

ABSTRACT

A contiguous diplexer is designed using a numerical optimization technique to meet the critical performance requirements of a spacecraft communication system. The diplexer consists of two, 3 section, bridge-coupled, singly terminated filters. The diplexer is realized in a coaxial structure whose measured performance is in good agreement with the predicted response.

Introduction

A diplexer is required to sum the outputs of two transmitters for a spacecraft communications application. The performance requirements are summarized in Table 1. Using the conventional design approach, the diplexing requirements can be met with two 3 section notch filters and the out-of-band rejection requirement can be met by adding a 3 section bandpass filter to the common output. However, it was reasoned that two 3 section bandpass filters could meet the same requirements and thus reduce the size and weight by a third. Because of the proximity of the signals (4 MHz separation) the filters need to be of a contiguous, single-ended design. Also, because the signal bandwidth is much less than the filter bandwidth, the filter's passband need not be equiripple. For these reasons a numerically optimized design is selected over the standard design techniques.

Table 1

Diplexer Performance Requirements

Ports	Frequency (MHz)	Loss (dB)
CH1 TO OUTPUT	2213.9 to 2214.1	≤ 1.4
	2208.6 to 2209.6	≥ 20
	2033.9 to 2034.5	≥ 55
CH2 TO OUTPUT	2208.6 to 2209.6	≤ 1.4
	2213.9 to 2214.1	≥ 20
	2033.9 to 2034.5	≥ 55

Electrical Design

The filter parameters are determined using a filter/multiplexer design program developed by Dr. E. Griffin. The program numerically optimizes each filter and multiplexer parameter against a prescribed performance requirement. Figure 1 shows the filter model used by the program. It is based on a model given in reference 1. Instead of the more common lossless, low pass prototype elements, the program uses lossy, bandpass resonators. The intercavity couplings are indicated in the same manner as reported in reference 2.

The resulting design is unique for two reasons. First, each filter provides high isolation at the other filter's passband frequency by means of a single loss pole at that frequency. This single loss pole is achieved by adding a bridge coupling between the first and third resonators which bridges an odd number of resonators. The effect of this bridge coupling and the proximity of the two channels cause the filter to become detuned. To regain the required match the resonators are asynchronously tuned. This is indicated in Figure 1 by the tuning capacitors C1. Second, the diplexer is matched over ± 6 MHz about the mean frequency; therefore, no annulling is required in this application. (Annulling is normally required to match the band edges.)

Realization

The diplexer is realized in a coaxial structure with 1.75 inch square cavities machined in a solid aluminum housing with .53 inch diameter resonators. The resonators are segmented from invar and aluminum to provide a temperature stability of less than 2.5 ppm/ $^{\circ}$ F. The input and common output ports are capacitively coupled. The positive couplings use inductive irises at the base of the resonators and the negative coupling uses a capacitive probe near the top of the resonators. The two rows of resonators are offset so that all couplings can be easily realized. (See Figure 2). The diplexer is tuned by first setting each coupling individually to the calculated values and then making minor adjustments to achieve the overall response.

Results

The theoretical return loss achieved by this design is very close to an equiripple response. Figure 3 shows that the computed and measured loss responses are in good agreement. The second loss pole is due to the diplexing of the two filters. Each filter by itself would produce only one loss pole. The slope of the out-of-band attenuation except for frequencies near the loss poles is very similar to that of a single, 3 section filter with one bridge coupling which is somewhat less than that of a 3 section Chebyshev filter as predicted.

Conclusion

In conclusion: a convenient, temperature compensated, low weight, coaxial structure which employs diagonal bridge couplings to achieve significant opposite channel rejection is used to realize a numerically optimized diplexer design.

Acknowledgements

The author wishes to thank Dr. Edward Griffin for his assistance with the electrical design and Dr. Frederick Young for his suggestions for the diplexer's realization.

References

- (1) G. L. Matthaei, L. Young, E.M.T. Jones, "Microwave Filters, Impedance - Matching Networks, and Coupling Structures," McGraw-Hill, 1964, pp. 484-485.
- (2) H. C. Bell, Jr., "Canonical Lowpass Prototype Network For Symmetric Coupled-Resonator Bandpass Filters," Electronics Letters, Vol. 10, No. 13, 27th June 1974, pp. 265-266.

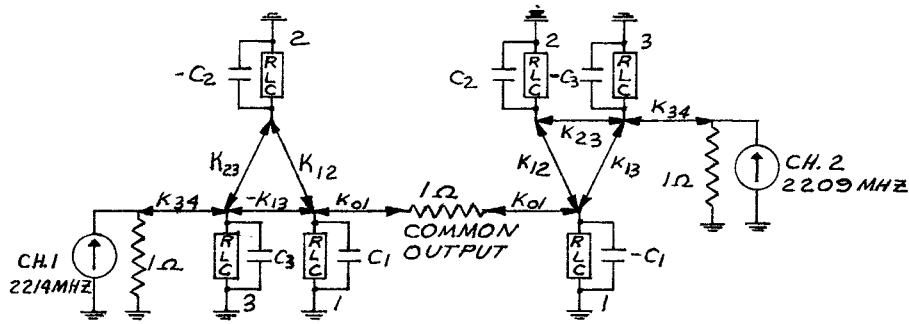

BAND PASS PROTOTYPE NETWORK
FIGURE 1

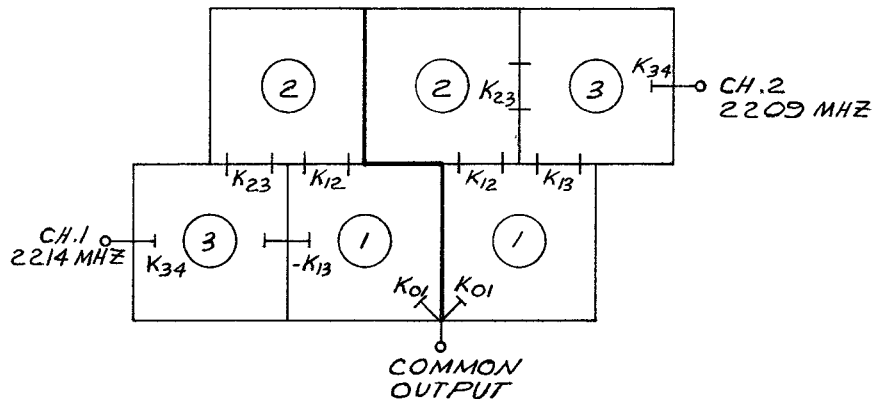

DIPLEXER CROSS SECTION
FIGURE 2

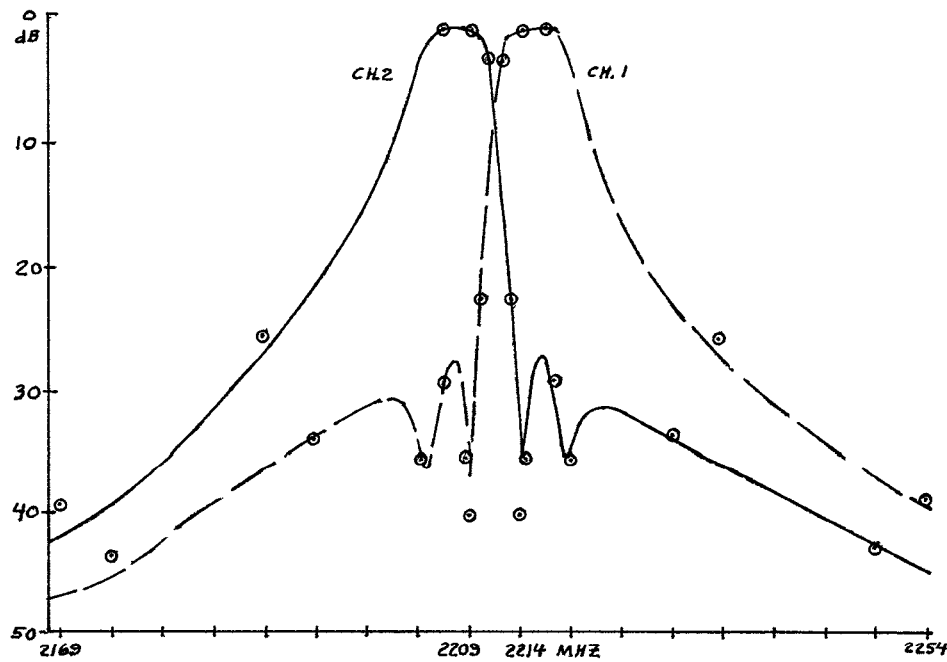

MEASURED AND PREDICTED
DIPLEXER LOSS VS. FREQUENCY
FIGURE 3